

EU Type Examination Certificate

No. 0200-MID-11310

LD 531 / BD 325 LCM / Px_DBy_Vz

AUTOMATIC GRAVIMETRIC FILLING INSTRUMENT

Issued by **FORCE Certification**
EU - Notified Body No. 0200

In accordance with the requirements in Directive 2014/32/EU of the European Parliament and Council.

Issued to Aymaksan Ayla Makina San. A.Ş.
Dudullu OSB 3.Cad. AND San. Sit. No:16/1
34776 Y.Dudullu-Ümraniye / Istanbul
TURKEY

In respect of An automatic gravimetric filling instrument designated **LD 531 / BD 325 LCM / Px_DBy_Vz** with variants of modules of load receptors, load cells and peripheral equipment.
Reference class 0.2
Maximum capacity, $n \times d$
Verification scale interval: $d \geq 1 \text{ g}$
Number of verification scale intervals: $n \leq 6000$, single-interval
(however, dependent on environment and the composition of the modules)
Variants of modules and conditions for the composition of the modules are set out in the annex.

The conformity with the essential requirements in Annex 1 and the specific requirements in Annex MI-006, chapter I & III of the Directive 2014/32/EU is met by the application of OIML R61-1:2004, section 12 & 13 of OIML D11:2004 and WELMEC Guide 7.2

Note: This certificate is a revision of DK0199.557 which it replaces.

The principal characteristics and approval conditions are set out in the descriptive annex to this certificate.

The annex comprises 34 pages.

Issued on **2021-11-19**
Valid until **2025-11-04**

Descriptive annex

Contents	Page
1. Name and type of instrument and modules	2
2. Description of the construction and function	2
2.1 Construction	2
2.2 Models	3
2.3 Functions	4
3. Technical data	5
3.1 LD 531 / BD 325 LCM / Px_DBy_Vz Automatic gravimetric filling instrument	5
3.2 Weighing controller	7
3.3 Load cells	8
3.4 Load receptors	9
3.5 Composition of modules	9
3.6 Documents	9
4. Interfaces and peripheral equipment	9
4.1 Interfaces	9
4.2 Peripheral equipment	9
5. Approval conditions	10
5.1 Compatibility of modules	10
6. Special conditions for verification	10
6.1 Composition of modules	10
7. Securing and location of seals and verification marks	10
7.1 Securing and sealing	10
8. Location of CE mark of conformity and inscriptions	10
8.1 Identification plate	10
9. Pictures	12
10. Composition of modules – an example	34

1. Name and type of instrument and modules

The automatic weighing instrument designated LD 531 / BD 325 LCM / Px_DBy_Vz automatic gravimetric filling instrument is consisting of the electronic weighing controller ECI connected to a separate load receptor and peripheral equipment such as printers or other devices, as appropriate.

The instrument is a self-indicating filling instrument with single-interval.

The modules appear from Sections 3.2, 3.3, and 3.4; the principle of the composition of the modules is set out in Sections 6.1 and 10.

2. Description of the construction and function

2.1 Construction

2.1.1 ECI weighing controller

The weighing controller of the ECI automatic gravimetric filling instrument is Esit's weighing controller type ECI.

Enclosures and keyboard

The enclosure of ECI is made of plastic. It is 149 mm wide x 84 mm high x 73 mm deep and is designed to mount in a flat panel.

ECI has 5 keys and the symbols of these are shown in the lower part of the display.

The rear panel of ECI contains all cable connectors.

Display

ECI has a 4.5 inch graphic LCD display (101×33 pixels) used for display of weight, indicators, key symbols, error messages and setup information.

Electronics

The weighing controller consists of a mainboard and 2 to 6 insertion modules.

The mainboard contains microprocessor control circuitry, keyboard, display, and non-volatile memory for program, set-up, and calibration parameters.

The module in slot 1 contains power supply, RS232 communication, and isolated remote display communication.

The module in slot 2 contains the analogue to digital load cell interface and an USB connection.

Slot 3 to 6 may contains optional I/O interfaces.

The module is specified in Section 3.2.

2.1.2 Load cells

Set out in Section 3.3.

2.1.3 Load receptor

Set out in Section 3.4.

2.1.4 Interfaces and peripheral equipment

Set out in Section 4.

2.2 Models

Px_DBy_Vz		Load cell type	No. of LCs	LC capacity	MaxFill
P1 & DB1	V1	SSP 80	1	80 kg	30 or 60 kg
P1 & DB2	V2	SSP20 / SSP 80	1	20 or 80 kg	5, 25 or 60 kg
P1 & DB3	V8	SSP 80	1	80 kg	30 kg
P1 & DB4	V9	SSP 80	1	80 kg	30 or 60 kg
P2 & DB1	V3	SSP20 / SSP 80	1	20 or 80 kg	5, 25 or 60 kg
P2 & DB2	V5	SSP 80	1	80 kg	30 or 60 kg
P2 & DB3	V7	SSP 80	1	80 kg	25 kg
P2 & DB4	V10	SSP20 / SSP 80	1	20 or 80 kg	5, 25 or 60 kg
P3 & DB1	V4	SP 500	1	500 kg	300 kg
P3 & DB2	V12	SP 500	1	500 kg	300 kg
P3 & DB3	V6	SP 500	1	500 kg	300 kg
P3 & DB4	V11	SP 500	1	500 kg	300 kg
P4 & DB1	V13	SP 200 / SP500	4	200 or 500 kg	500 to 1500 kg
P4 & DB2	V14	SP 200 / SP500	4	200 or 500 kg	500 to 1500 kg
P4 & DB3	V15	SP 200 / SP500	4	200 or 500 kg	500 to 1500 kg
P4 & DB4	V16	SP 200 / SP500	4	200 or 500 kg	500 to 1500 kg
P5 & DB1	V17	BS 1000	4	1000 kg	1500 kg
P5 & DB2	V18	BS 1000	4	1000 kg	1500 kg
P5 & DB3	V19	BS 1000	4	1000 kg	1500 kg
P5 & DB4	V20	BS 1000	4	1000 kg	1500 kg

2.3 Functions

The main functions are described below.

2.3.1 Functions and devices

The automatic weighing instrument has the following permitted functions and devices that are subject to the Measuring Instrument Directive:

- Power up test
- Initial zero setting device (max. 20 % of Max)
- Semiautomatic zero setting device (max 4 % of Max)
- Zero tracking device (max 4 % of Max)
- Automatic zero setting device (max 4 % of Max)
- No motion detection and indication
- Automatic tare device
- Coarse filling device
- Fine filling device
- Stop mode (for check and verification purpose)
- Detection of significant fault

2.3.2 Software version

The software version of the ECI weighing controller is displayed at start-up.
The approved software version is 1.4.x

3. Technical data

The automatic weighing instruments and its modules are set out as follows:

3.1 LD 531 / BD 325 LCM / Px_DBy_Vz Automatic gravimetric filling instrument

Type:	LD 531 / BD 325 LCM/ Px_DBy_Vz automatic gravimetric filling instrument
Weighing controller:	ECl
Reference class:	0.2
Accuracy class:	0.2 or 0.5 or 1 or 2
Maximum capacity (Max):	$n \times d$
Maximum Fill (MaxFill):	$\leq \text{Max}$
Minimum Fill (MinFill):	See tables below
Minimum capacity (Min):	$= \text{Minfill}$
Verification scale interval (d):	$\geq 1 \text{ g}$
Filling speed:	up to 20 fills/min
Weighing range:	Single-interval
Number of Verification Scale Intervals (n):	≤ 6000
Loads per fill:	1
Maximum tare effect:	$\leq 100 \% \text{ of Max}$
Temperature range:	$-10^\circ \text{ to } 40^\circ \text{ C}$
Weighing mode:	Static
Electromagnetic class:	E2
Humidity:	Non-condensing
Maximum time between automatic zero-setting:	See tables below
Extra warm-up time:	See tables below

MinFill's dependency of accuracy class, d in g and d in μV .

MinFill for:

verification scale interval (d):	$1.0 \leq d < 1.6 \mu\text{V}$
extra warm-up time:	$\geq 4 \text{ minutes}$
maximum time between auto-zero:	$\leq 100 \text{ minutes}$

d	Accuracy class							
	X(0.2)		X(0.5)		X(1)		X(2)	
	[g]	[kg]	[g]	[kg]	[g]	[kg]	[g]	[kg]
1	178	0.178	36	0.036	18	0.018	9	0.009
2	534	1.068	72	0.144	18	0.036	9	0.018
5	534	2.670	214	1.070	36	0.180	9	0.045
10	534	5.34	214	2.14	107	1.07	18	0.18
20	800	16.00	214	4.28	107	2.14	54	1.08
50	800	40.00	320	16.00	107	5.35	54	2.70
100	800	80.0	320	32.0	160	16.0	54	5.4
≥ 200	800		320		160		80	

MinFill for:

verification scale interval (d): $1.0 \leq d < 1.6 \mu\text{V}$
 extra warm-up time: None
 maximum time between auto-zero: ≤ 120 minutes

d	Accuracy class							
	X(0.2)		X(0.5)		X(1)		X(2)	
	[g]	d	[kg]	d	[kg]	d	[kg]	d
1	1598	1.598	320	0.320	107	0.107	27	0.027
2	1598	3.196	639	1.278	160	0.320	54	0.108
5	1598	7.990	639	3.195	320	1.600	80	0.400
10	2396	23.96	639	6.39	320	3.20	160	1.60
20	2396	47.92	959	19.18	320	6.40	160	3.20
50	2396	119.80	959	47.95	479	23.95	160	8.00
100	2396	239.6	959	95.9	479	47.9	240	24.0
≥ 200	2396		959		479		240	

MinFill for:

verification scale interval (d): $d \geq 1.6 \mu\text{V}$
 extra warm-up time: ≥ 4 minutes
 maximum time between auto-zero: ≤ 100 minutes

d	Accuracy class							
	X(0.2)		X(0.5)		X(1)		X(2)	
	[g]	d	[kg]	d	[kg]	d	[kg]	d
1	112	0.112	23	0.023	12	0.012	6	0.006
2	167	0.334	23	0.046	12	0.024	6	0.012
5	334	1.670	67	0.335	23	0.115	6	0.030
10	334	3.34	134	1.34	34	0.34	12	0.12
20	334	6.68	134	2.68	67	1.34	17	0.34
50	500	25.00	134	6.70	67	3.35	34	1.70
100	500	50.0	200	20.0	67	6.7	34	3.4
≥ 200	500		200		100		34	

MinFill for:

 verification scale interval (d): $d \geq 1.6 \mu\text{V}$
 extra warm-up time: None
 maximum time between auto-zero: ≤ 120 minutes

d	Accuracy class							
	X(0.2)		X(0.5)		X(1)		X(2)	
	[g]	d	[kg]	d	[kg]	d	[kg]	d
1	500	0.500	134	0.134	34	0.034	17	0.017
2	999	1.998	200	0.400	67	0.134	17	0.034
5	999	4.995	400	2.000	100	0.500	34	0.170
10	999	9.99	400	4.00	200	2.00	50	0.50
20	1498	29.96	400	8.00	200	4.00	100	2.00
50	1498	74.90	999	29.95	200	10.00	100	5.00
100	1498	149.8	999	59.9	300	30.0	100	10.0
≥ 200	1498		599		300		150	

3.2 Weighing controller

The weighing controller has the following characteristics:

 Type: ECI
 Accuracy class: III
 Weighing range: Single interval
 Maximum number of Verification Scale intervals: 10 000
 Maximum subtractive tare effect: -Max, within display limits
 Fractional factor: $p'i = 0.5$
 Minimum input voltage per VSI: $1.0 \mu\text{V}$
 Minimum input voltage: 0 mV
 Excitation voltage: 10 VDC
 Analogue range: ± 100 mV
 Circuit for remote sense: Active
 Minimum input impedance: 35 ohm
 Maximum input impedance: 1100 ohm
 Internal resolution: $> 8\,000\,000$ counts
 Operating temperature range: $-10 \text{ }^\circ\text{C}$ to $+40 \text{ }^\circ\text{C}$
 Mains power supply: 12 - 24 VDC
 Peripheral interface: Set out in Section 4

3.2.1 Connecting cable between the weighing controller and a junction box for load cell(s), if any

3.2.1.1 4-wire system

Cable between Weighing controller and load cell(s): 4 wires (no sense), shielded

Cable length: The certified length of the load cell cable.

3.2.1.2 6-wire system

Cable between Weighing controller and load cell(s): 6 wires (sense), shielded

Maximum cable length between weighing controller and junction box (J-box) for load cell(s), if any:

- Option 1: 420 m/mm²

In case the (n) for the weighing instrument is less than (n) mentioned above, the following apply:

- Option 2:

Coefficient of temperature of the span error of the weighing controller: $E_s = 0.0005$ [% / 25K]

Coefficient of resistance for the wires in the J-box cable: $S_x = 0.0049$ [% / ohm]

$L/A_{max} = 295.86 / S_x * (emp / n - E_s)$ [m / mm²] in which $emp = p'I * mpe * 100 / e$

From this, the maximum cable length for the weighing instrument may be calculated with regard to (n) for the actual configuration of the instrument.

Reference: See Section 10.

The calculation program is obtainable by downloading at www.delta.dk/weighing.

3.3 Load cells

3.3.1 General acceptance of load cells

Any load cell(s) may be used for instruments under this certificate of type approval provided the following conditions are met:

- 1) There is a respective certificate (EC or PC) or an OIML R60 Certificate of Conformity issued for the load cell by a Notified Body responsible for type examination under Directive 2014/31/EU
- 2) The certificate contains the load cell types and the necessary load cell data required for the manufacturer's declaration of compatibility of modules.
A load cell marked NH is allowed only if humidity testing to EN 45501 has been conducted on this load cell.
- 3) The compatibility of load cells and indicator is established by the manufacturer by means of the compatibility of modules form, contained in Annex F of the EN45501:2015 at the time of EU verification or declaration of EU conformity of type.
- 4) The load transmission must conform to one of the examples shown in the WELMEC Guide 2.4.

3.4 Load receptors

Movable platforms shall be equipped with level indicators.

3.4.1 Bin, tank, and hopper load receptors

Construction in brief:	Load cell assemblies each consisting of a load cell stand assembly to support one of the mounting feet or suspension points of bin, tank or hopper.
Reduction ratio:	1
Junction box:	Mounted in, on or near the dead load.
Load cell:	Any R60 certified load cell according to Section 3.2.1.
Drawings:	Various.

3.4.2 Bag load receptors

Construction in brief:	Load cell assemblies each consisting of a load cell stand assembly to support one of the suspension points of the bag to be filled.
Reduction ratio:	1
Junction box:	Mounted in, on or near the dead load.
Load cell:	Any R60 certified load cell according to Section 3.2.1.
Drawings:	Various.

3.5 Composition of modules

In case of composition of modules, EN 45501 paragraph 3.5 and 4.12 shall be satisfied.

3.6 Documents

The documents filed at FORCE (reference No. T209554 and 121-30461) are valid for the weighing instruments described here.

4. Interfaces and peripheral equipment

4.1 Interfaces

One or more of the following interfaces may be incorporated. The interfaces are protective interfaces within the meaning of 2014/32/EU annex I, sect. 8.1 and need not to be secured.

The weighing controller may be equipped with one or more of the following protective interfaces located on the main board or on separate interface boards.

- RS-232C
- RS-485 / RS-422
- USB
- Modbus (optional)
- Profibus (optional)
- Ethernet IP (optional)
- Analogue Output (optional)
- Digital I/O (optional)

4.2 Peripheral equipment

Connection between the weighing controller and peripheral equipment shall be done by screened cables.

The instrument may be connected to any simple peripheral device with a CE mark of conformity.

5. Approval conditions

5.1 Compatibility of modules

Composition of modules, EN 45501:2015, annex F shall be satisfied.

6. Special conditions for verification

6.1 Composition of modules

The environmental conditions should be taken into consideration by the composition of modules for a complete weighing instrument, for example instruments with load receptors placed outdoors and having no special protection against the weather.

The composition of modules shall agree with Section 5.2.

An example of a declaration of conformity document is shown in Section 10.

7. Securing and location of seals and verification marks

7.1 Securing and sealing

Seals shall bear the verification mark of a notified body or alternative mark of the manufacturer according to ANNEX II, section 2 or 4 of the Directive 2014/32/EU.

7.1.1 Weighing controller

Access to the configuration and calibration facilities is achieved by sealing the access to calibration switch with a sticker.

Sealing of the enclosure - to secure the electronics against dismantling/adjustment - is accomplished with a brittle plastic sticker across the assembly of the enclosure.

7.1.2 Weighing controller - load cell connector - load receptor

Securing of the load cell connector with the weighing controller is done by means of a brittle sticker.

7.1.3 Junction box for load cells

The junction box, if any, is sealed by means of brittle stickers or lead seals.

7.1.4 Peripheral interfaces

All peripheral interfaces are "protective"; they neither allow manipulation with weighing data or Legal Setup, nor change of the performance of the weighing instrument in any way, which would alter the legality of the weighing.

8. Location of CE mark of conformity and inscriptions

8.1 Identification plate

All inscriptions for the instrument shall be placed on the identification plate, which is located on the display module.

8.1.1 CE mark and metrological M

A CE mark of conformity grouped together with space for the metrological M and year of production shall be located on the identification plate.

8.1.2 Inscriptions

The identification plate shall bear the following inscriptions:

- Manufacturer's name and postal address
- Type designation
- Serial number
- Accuracy class
- Max, Minfill and d (these shall additional be duplicated near the display unless the description plate is located near the display)
- Temperature range: -10 °C / +40 °C
- Electromagnetic class: E2
- Humidity: Non-condensing
- Maximum filling speed
- Type examination certificate number

9. Pictures



Figure 1. ECI weighing controller for automatic gravimetric filling instrument.

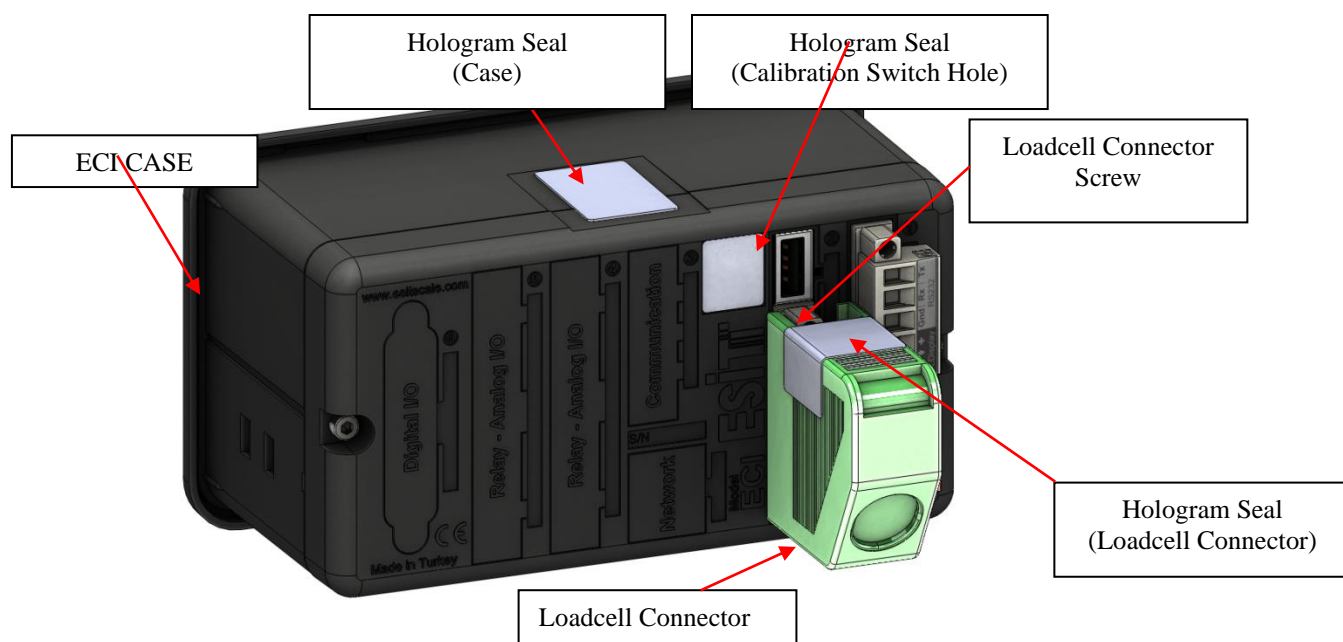

Figure 2 Sealing of ECI weighing controller.

0200-MID-11310

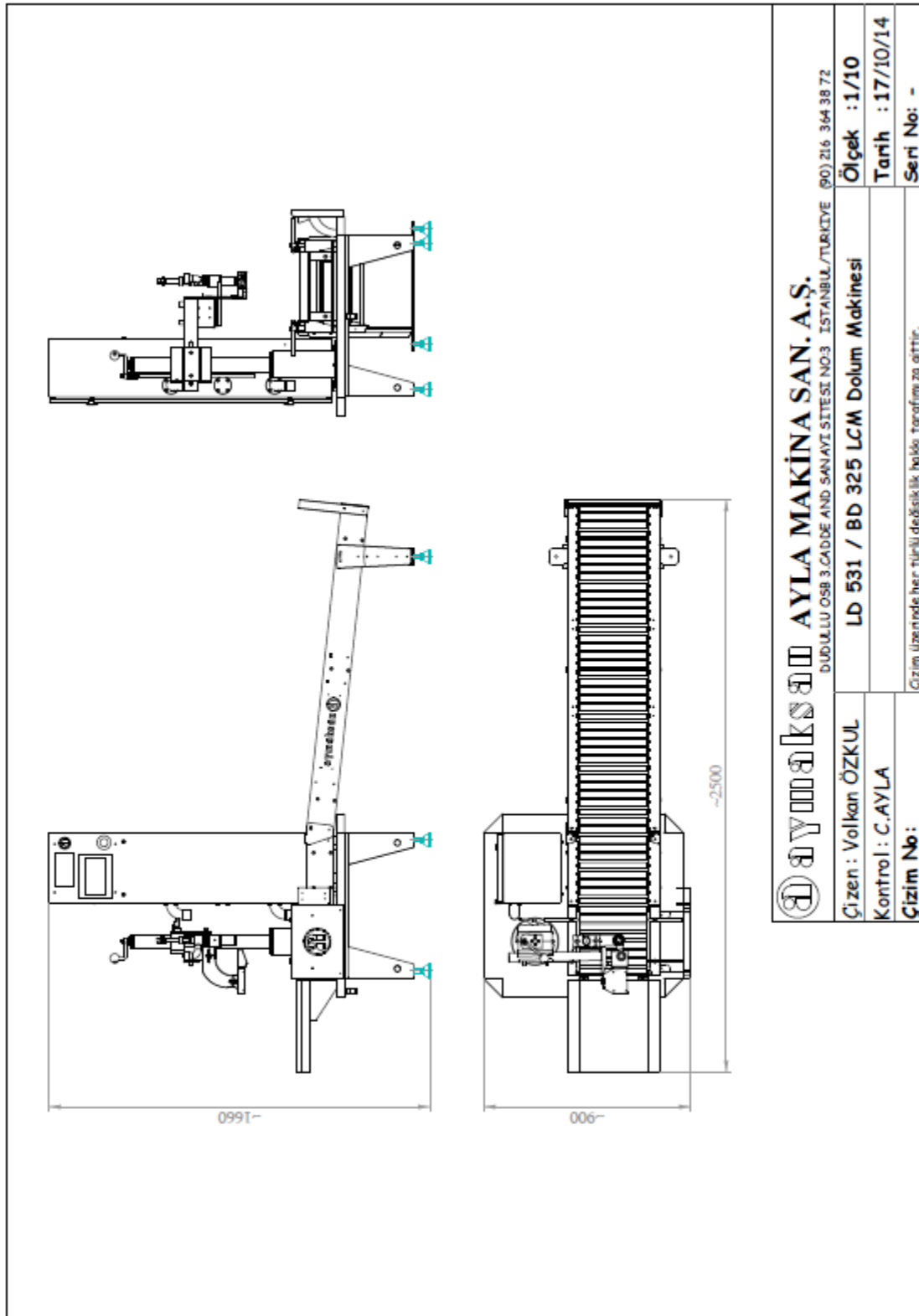
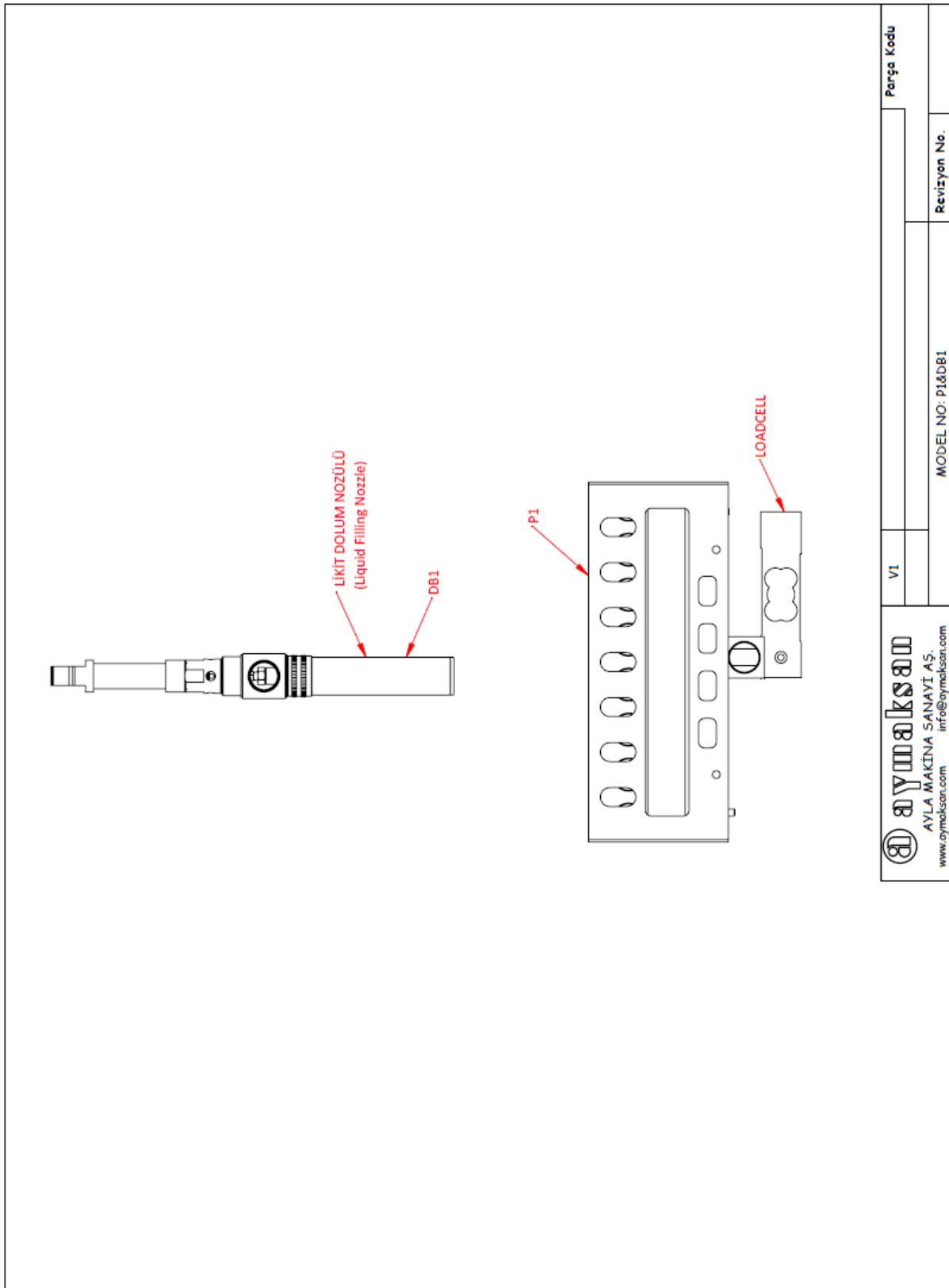

Figure 3. LD 531/ BD 325 LCM automatic gravimetric filling instrument.



Ferçe Kodu	
V1	MODEL NO: P1&DB1
Revizyon No.	
 AYTA MAKİNA AYLA MAKİNA SANAYİ A.Ş. www.aymakina.com info@aymakina.com	

Figure 4. P1_DB1_V1 automatic gravimetric filling instrument.

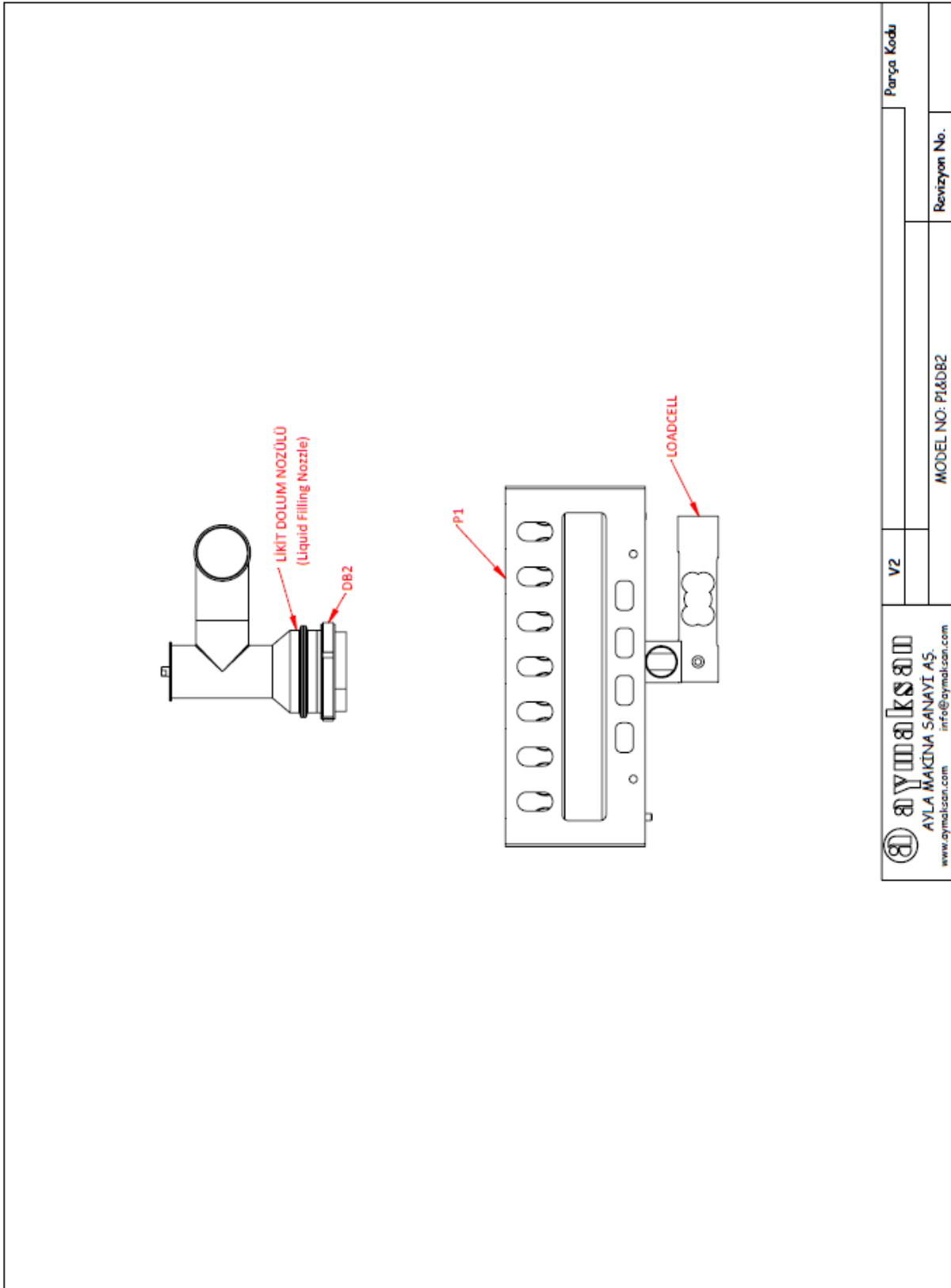
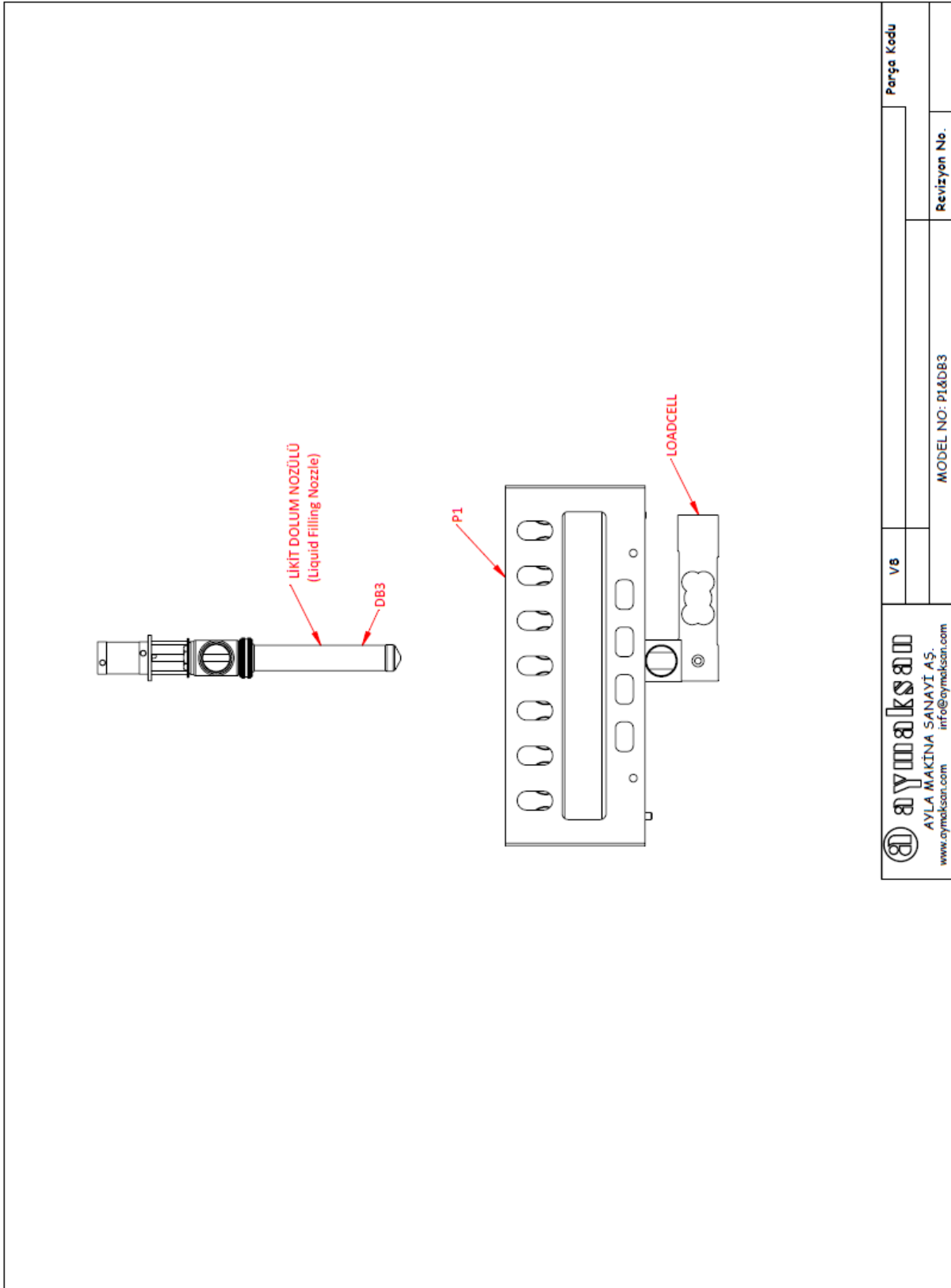

Figure 5. P1_DB2_V2 automatic gravimetric filling instrument.

Parça Kodu	
V2	Revizyon No.
MODEL NO: P1&DB2	
 AYMLAŞAN AYLA MAKİNA SANAYİ A.Ş. www.aymlaşan.com info@aymlaşan.com	

0200-MID-11310



Parça Kodu	
Revizyon No.	
MODEL NO: P1&DB3	
V8	
 ayymakşan AYLA MAKİNA SANAYİ A.Ş. www.aymakşan.com info@aymakşan.com	

Figure 6. P1_DB3_V8 automatic gravimetric filling instrument.

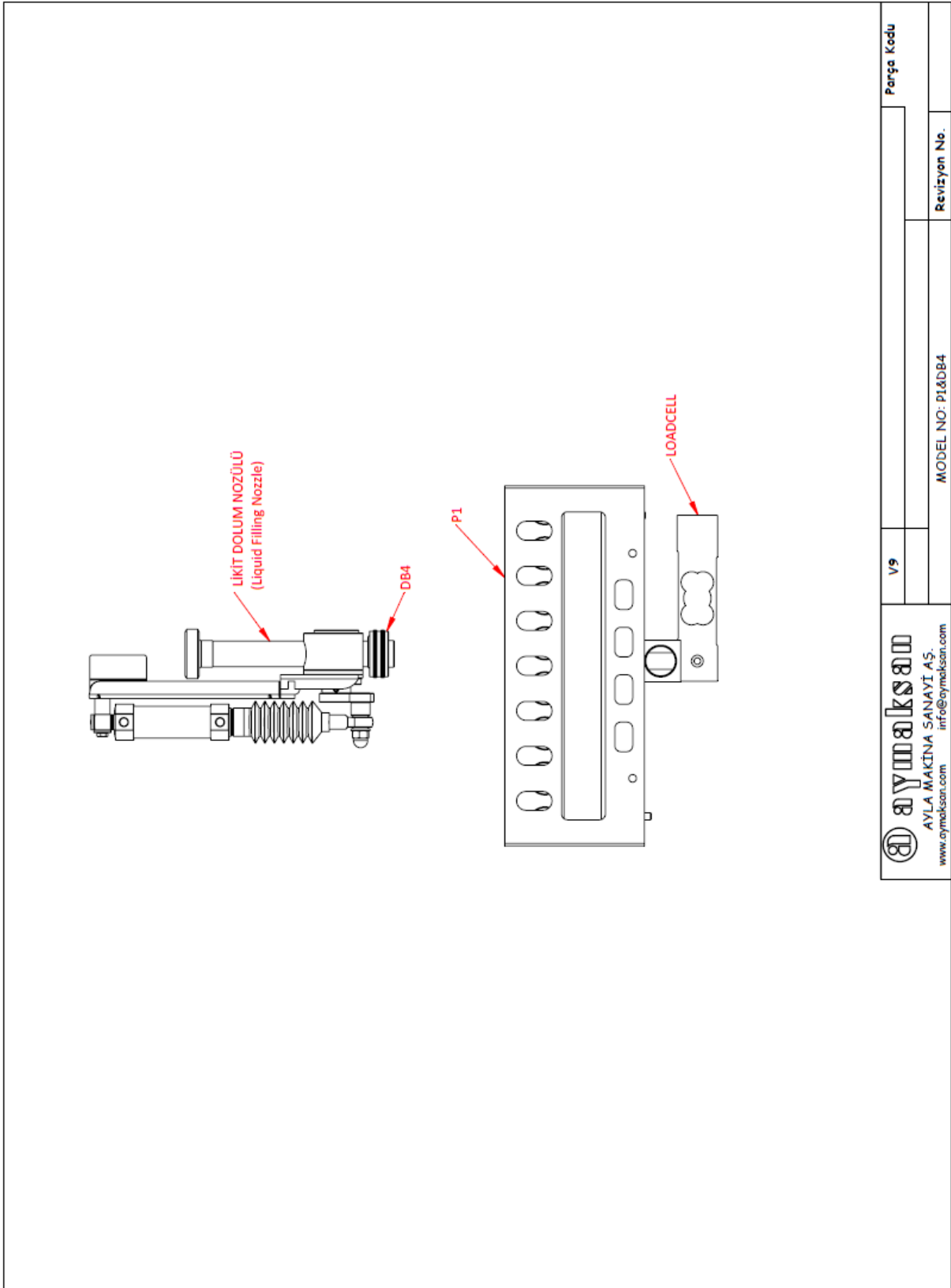

Figure 7. P1_DB4_V9 automatic gravimetric filling instrument.

Parça Kodu	V9	MODEL NO: P1&DB4	Revizyon No.
 aymaksoo AYLA MAKİNA SANAYİ A.Ş. www.aymaksoo.com info@aymaksoo.com			

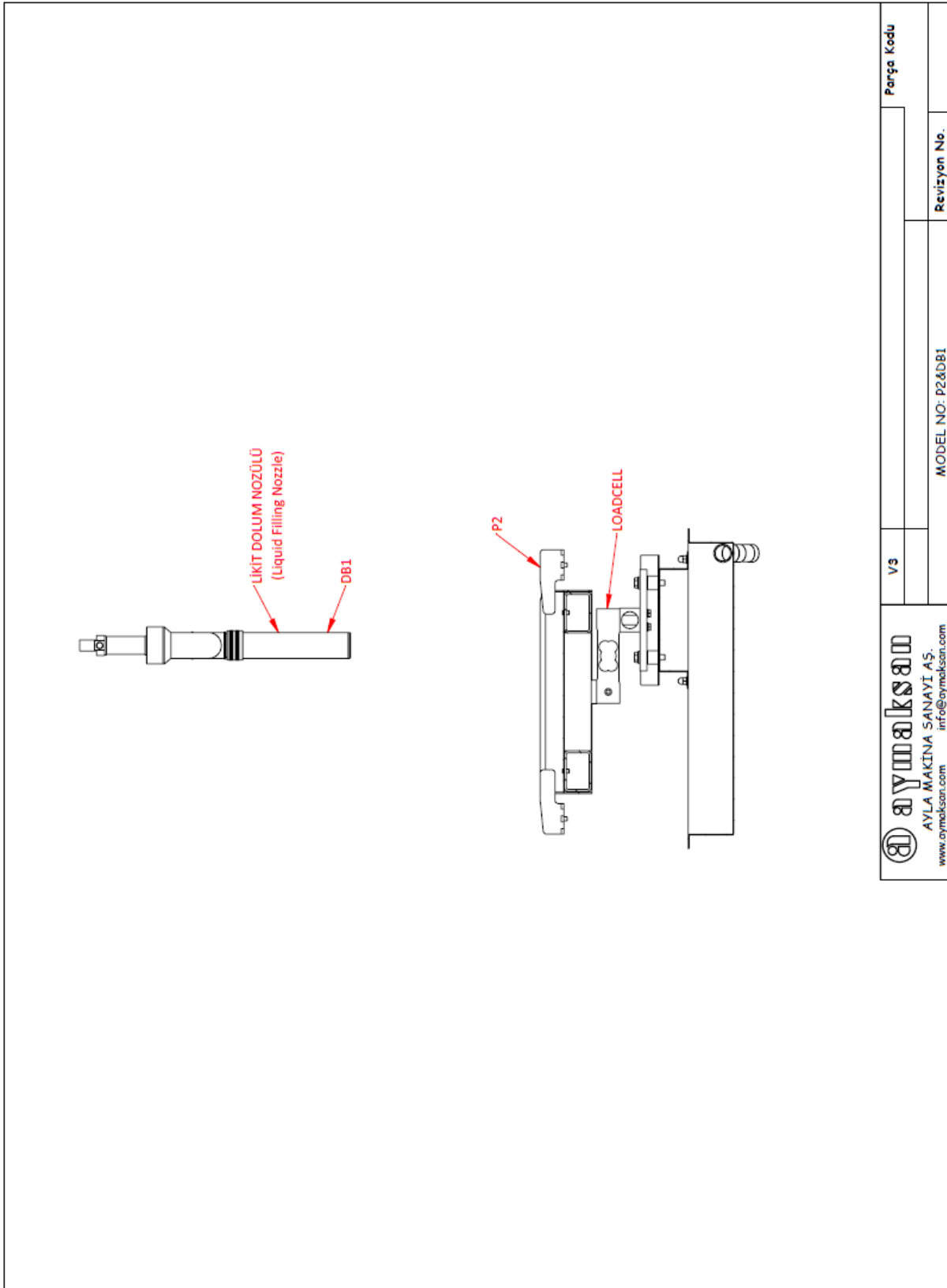

Figure 8. P2_DB1_V3 automatic gravimetric filling instrument.

 AYTA MAKİNA AYLA MAKİNA SANAYİ A.Ş. www.aymakina.com info@aymakina.com	V3	MODEL NO: P2&DB1	Revizyon No.
			Paraç Kodu

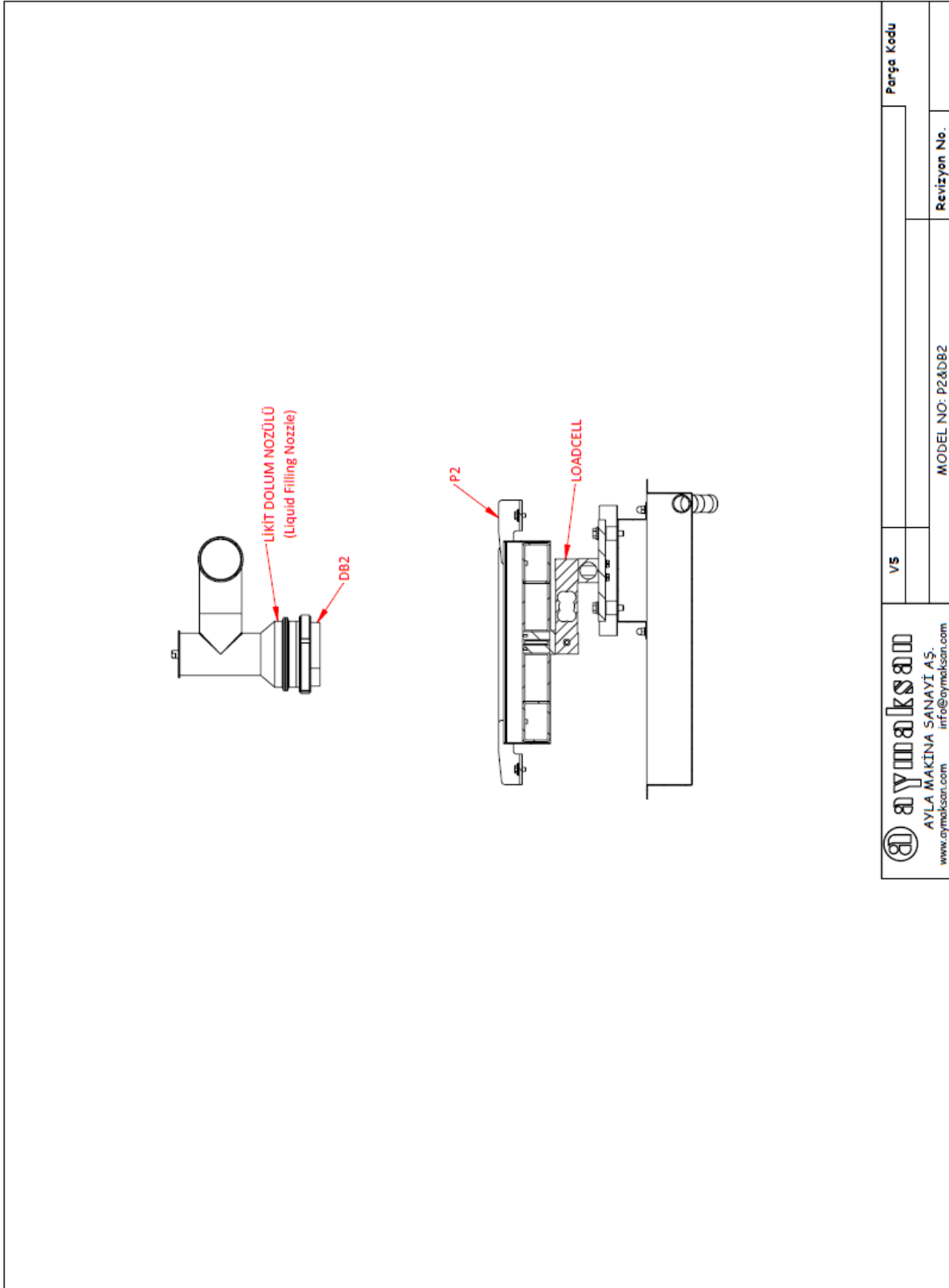

Figure 9. P2_DB2_V5 automatic gravimetric filling instrument.

 AYTAÇ MAKİNA SANAYİ A.Ş. www.aymak.com info@aymak.com	V5	MODEL NO: P2&DB2	Revizyon No.
			Parça Kodu

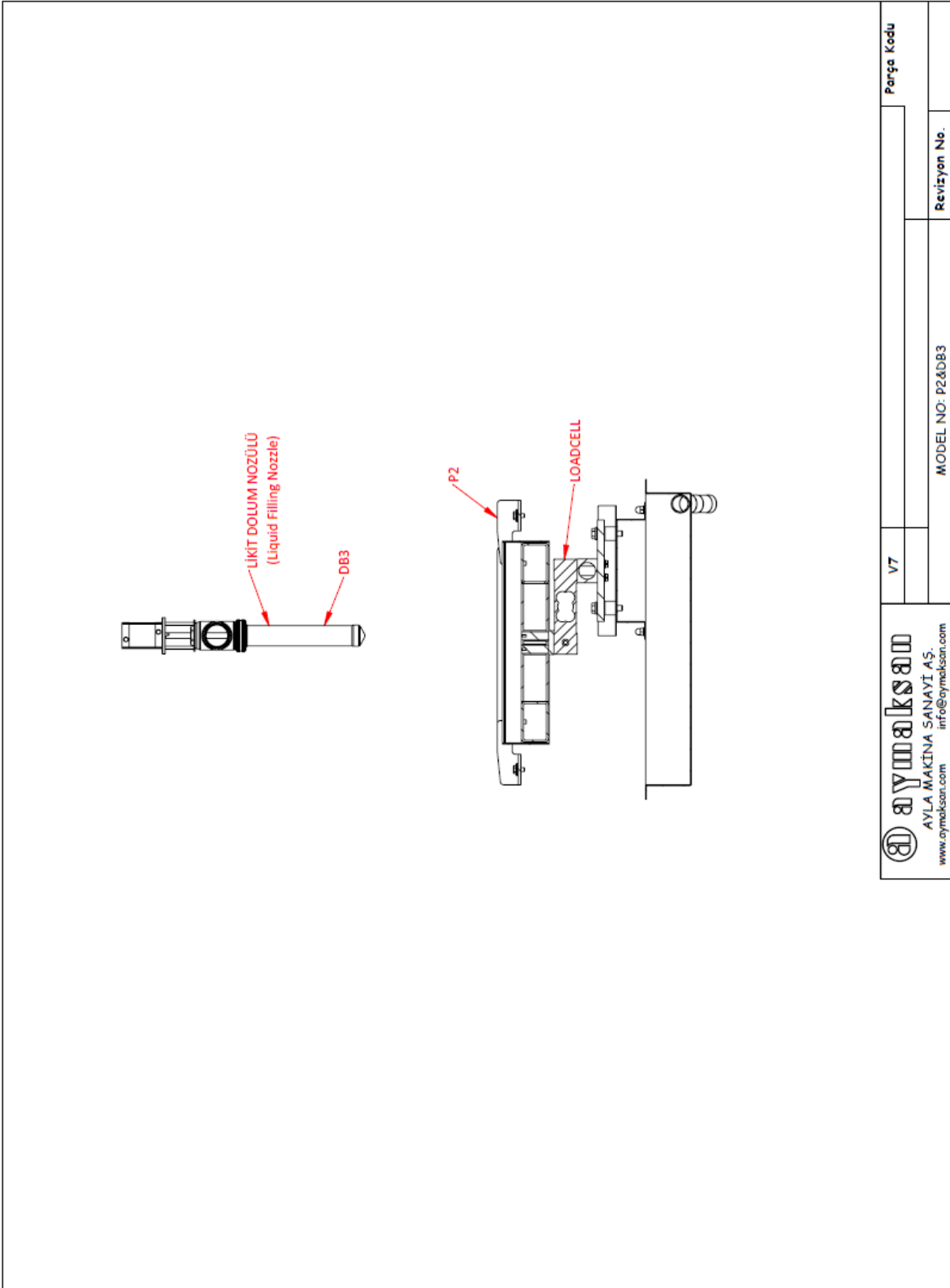

Figure 10. P2_DB3_V7 automatic gravimetric filling instrument.

 aytaç makina sanayi a.ş. AYLA MAKİNA SANAYİ A.Ş. www.aymakina.com info@aymakina.com	V7	Parça Kodu
		Revizyon No.
MODEL NO: P2&DB3		

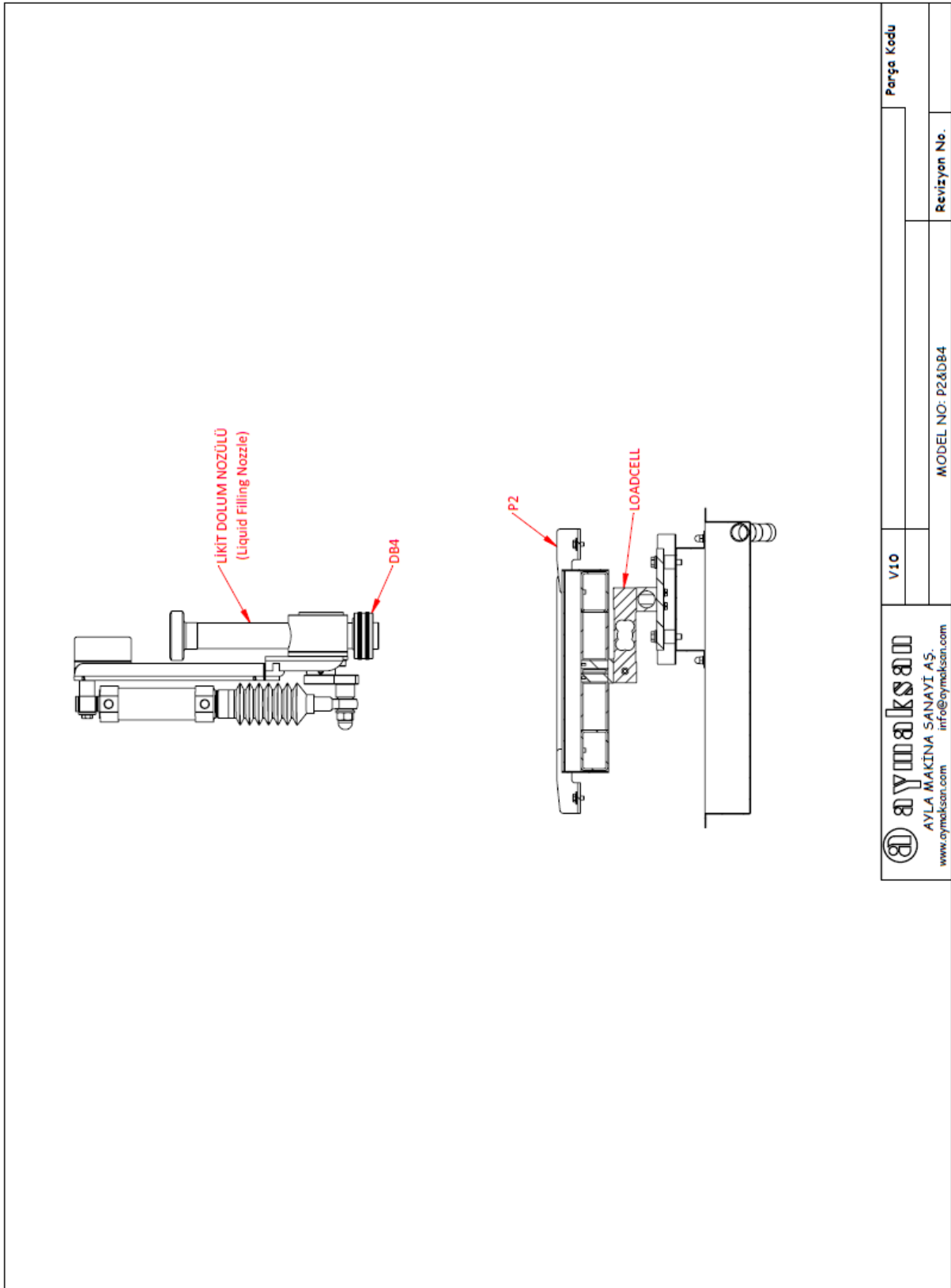

Figure 11. P2_DB4_V10 automatic gravimetric filling instrument.

 aytaçsarı AYLA MAKİNA SANAYİ A.Ş. www.aytasari.com info@aytasari.com	V10	Parça Kodu
		Revizyon No.
MODEL NO: P2&DB4		

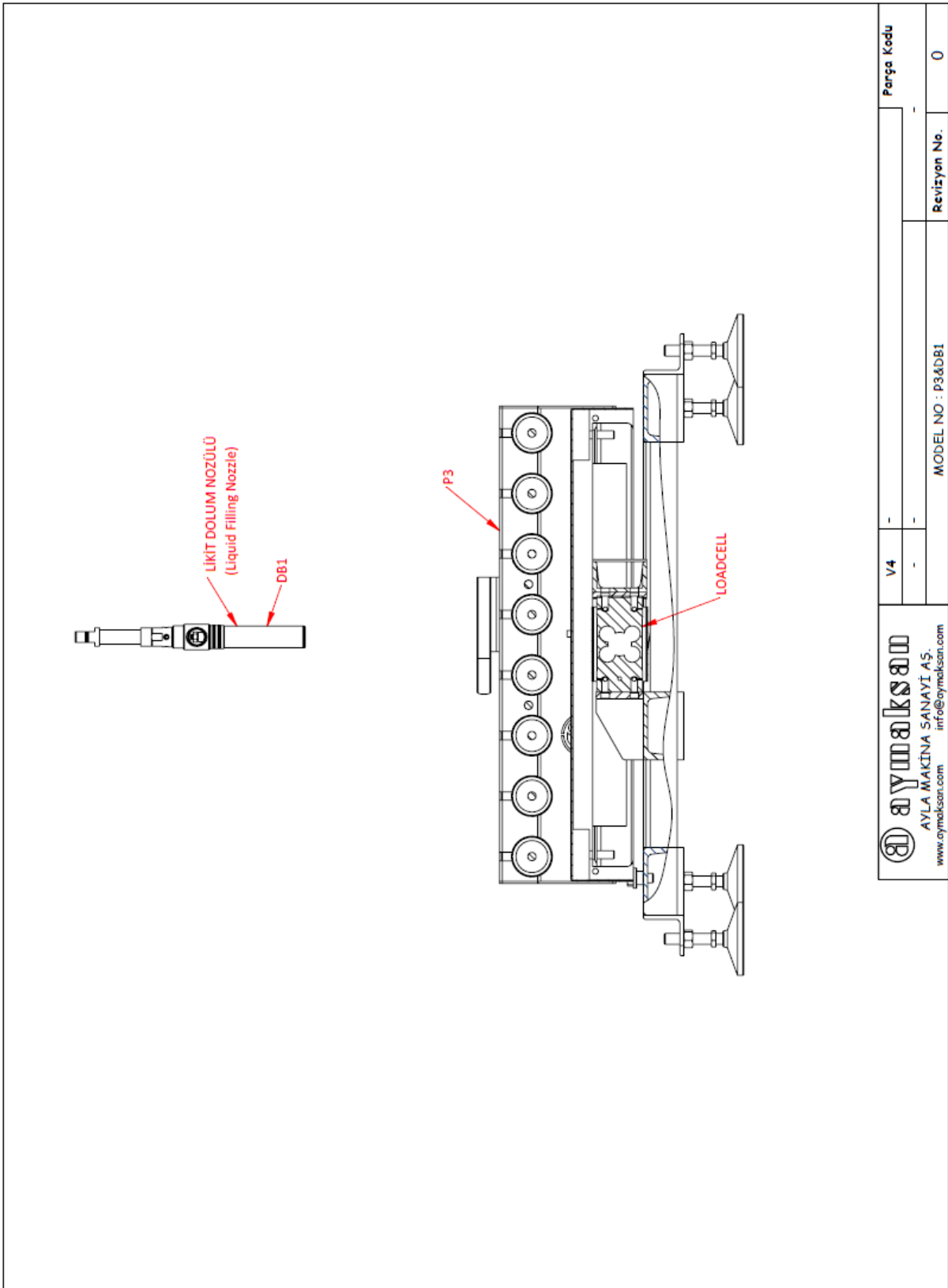
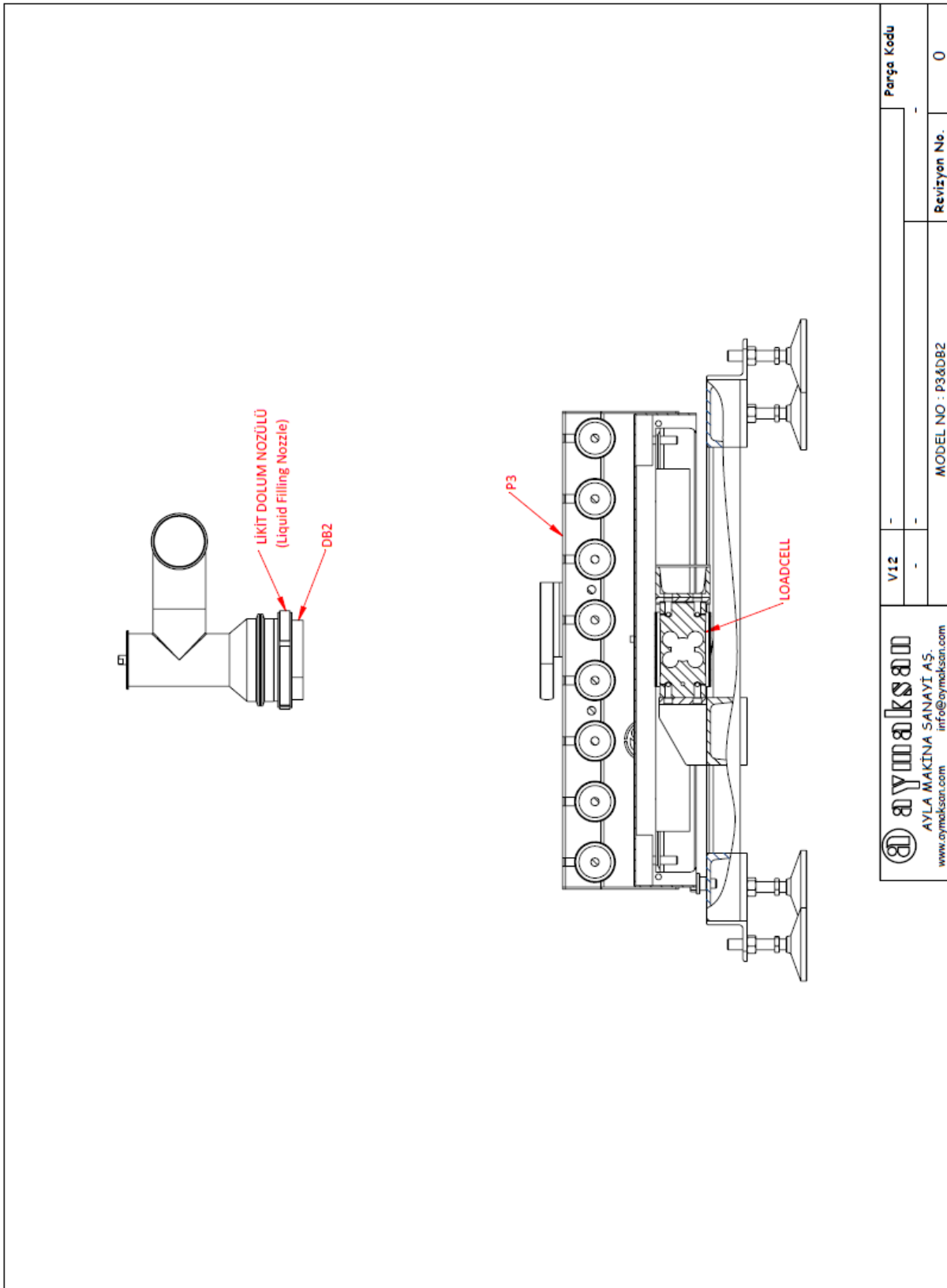

Figure 12. P3_DB1_V4 automatic gravimetric filling instrument.

 AYMAKSAN AYLA MAKİNA SANAYİ A.Ş. www.aymaksan.com info@aymaksan.com	V4	-	Parça Kodu
	-	-	-
MODEL NO : P3&DB1			Revizyon No.
			0



 GYMKSAN AYLA MAKİNA SANAYİ A.Ş. www.gymksan.com info@gymksan.com	V12	-	Parça Kodu
	-	-	-
		MODEL NO : P3&DB2	Revizyon No.
			0

Figure 13. P3_DB2_V12 automatic gravimetric filling instrument.

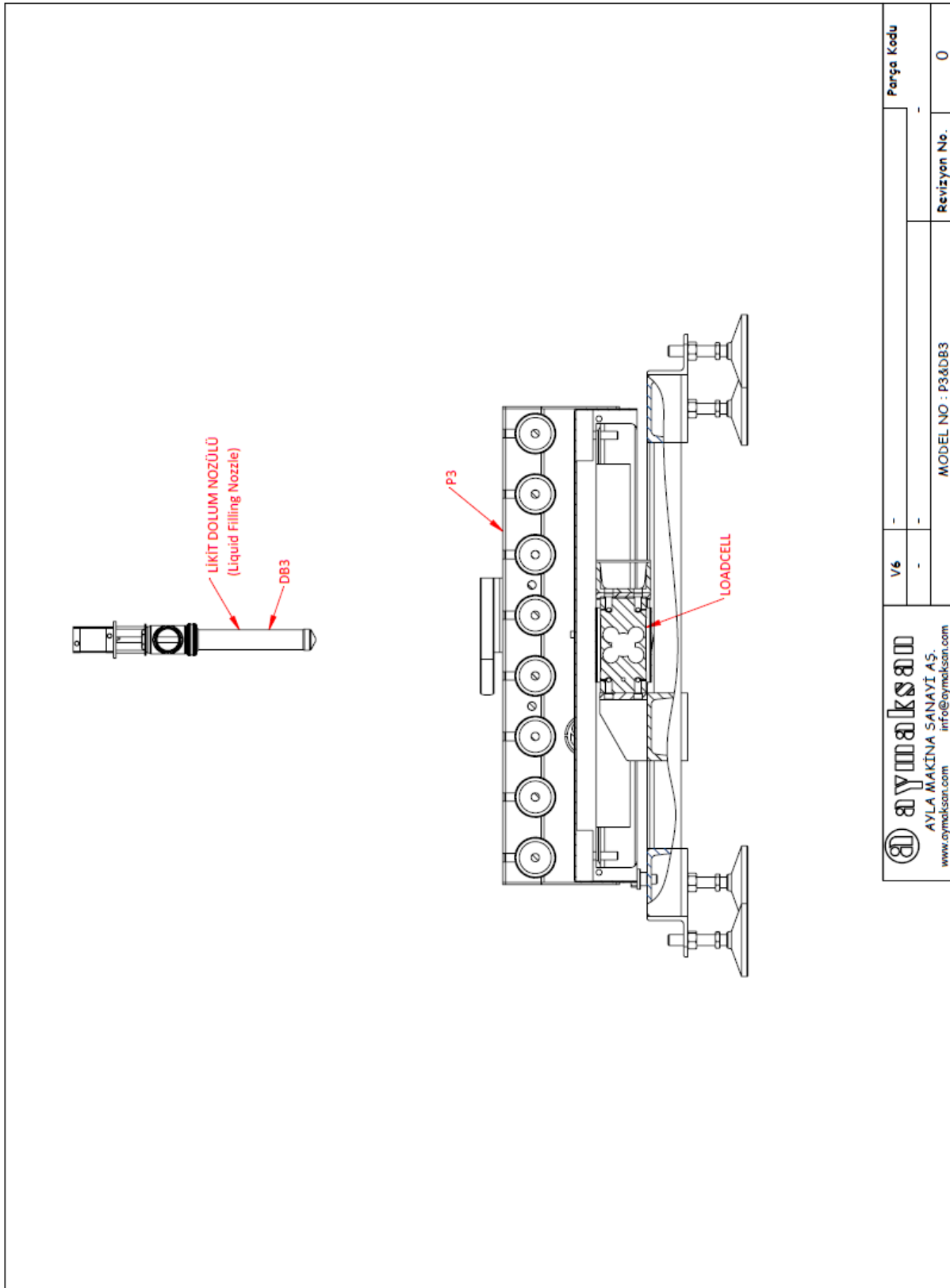

Figure 14. P3_DB3_V6 automatic gravimetric filling instrument.

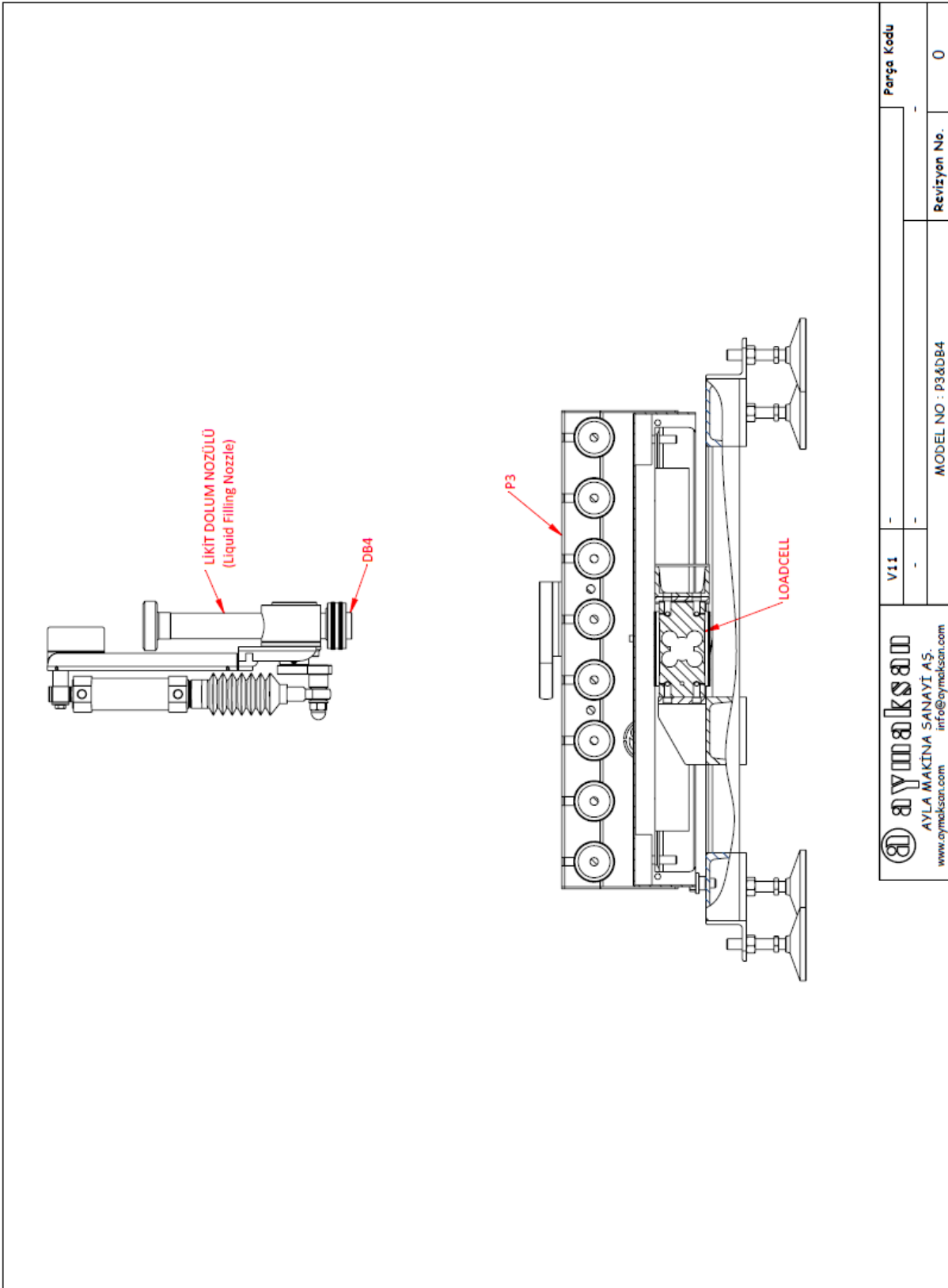

Figure 15. P3_DB4_V11 automatic gravimetric filling instrument.

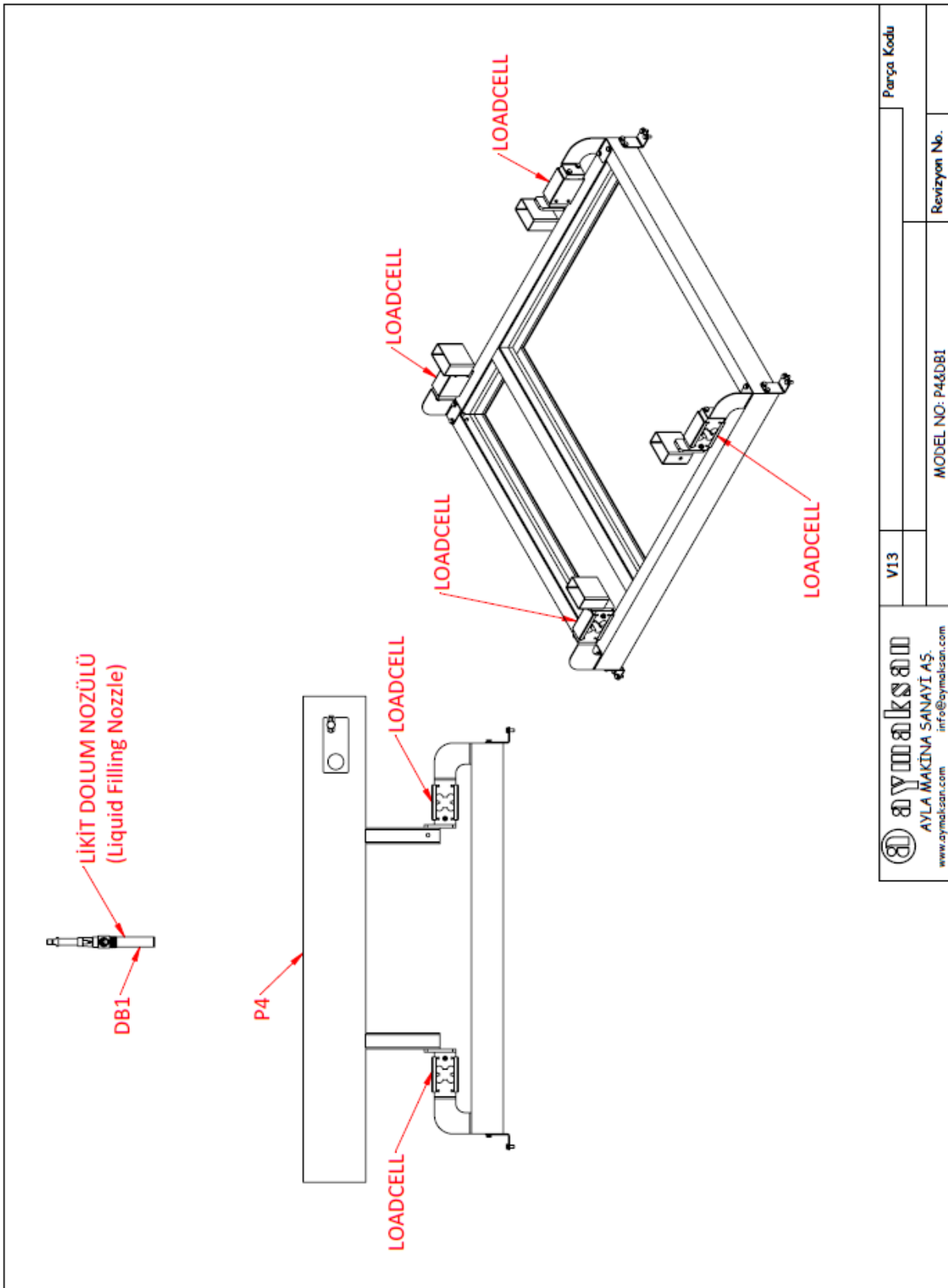

Figure 16. P4_DB1_V13 automatic gravimetric filling instrument.

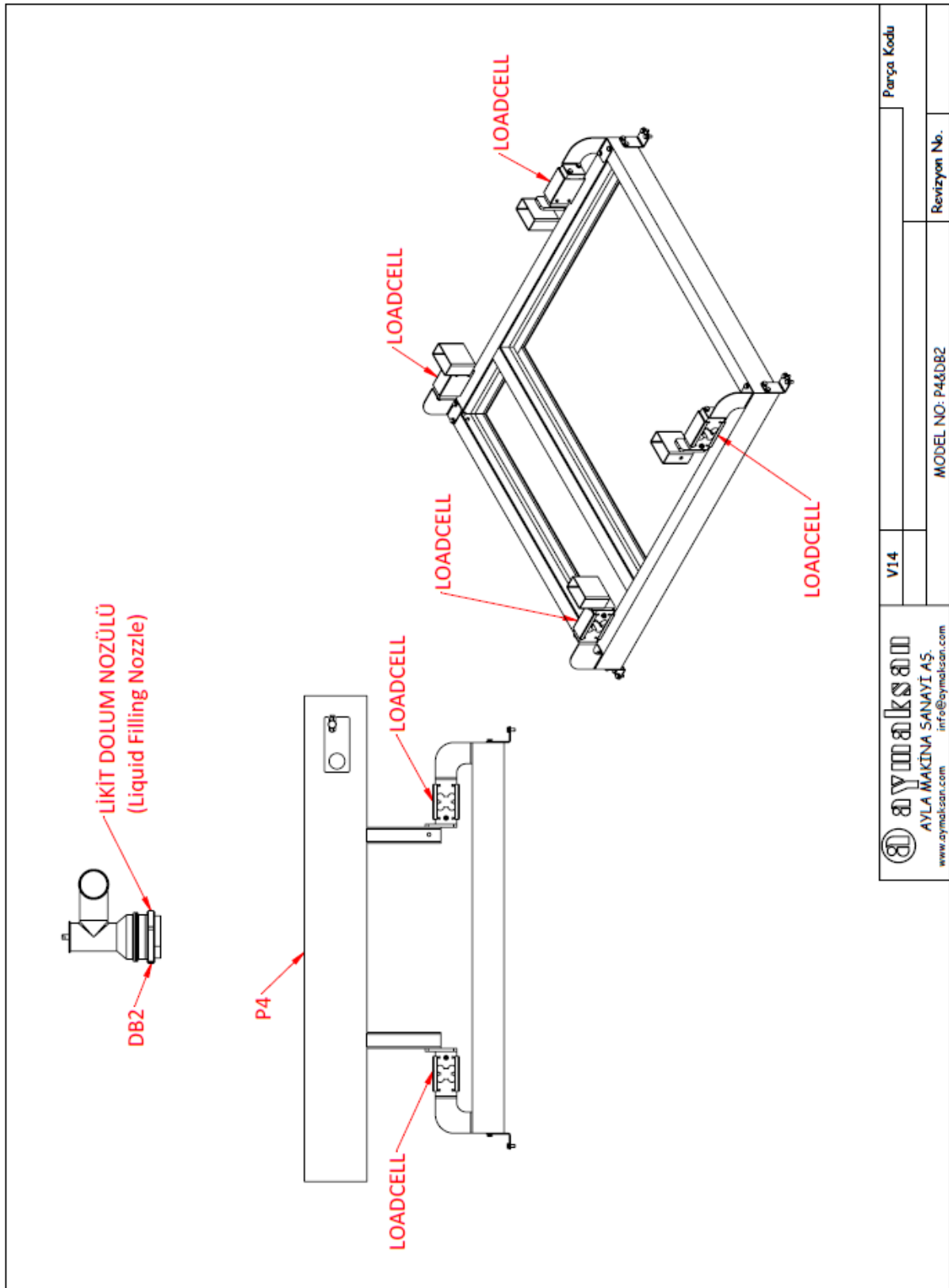

Figure 17. P4_DB2_V14 automatic gravimetric filling instrument.

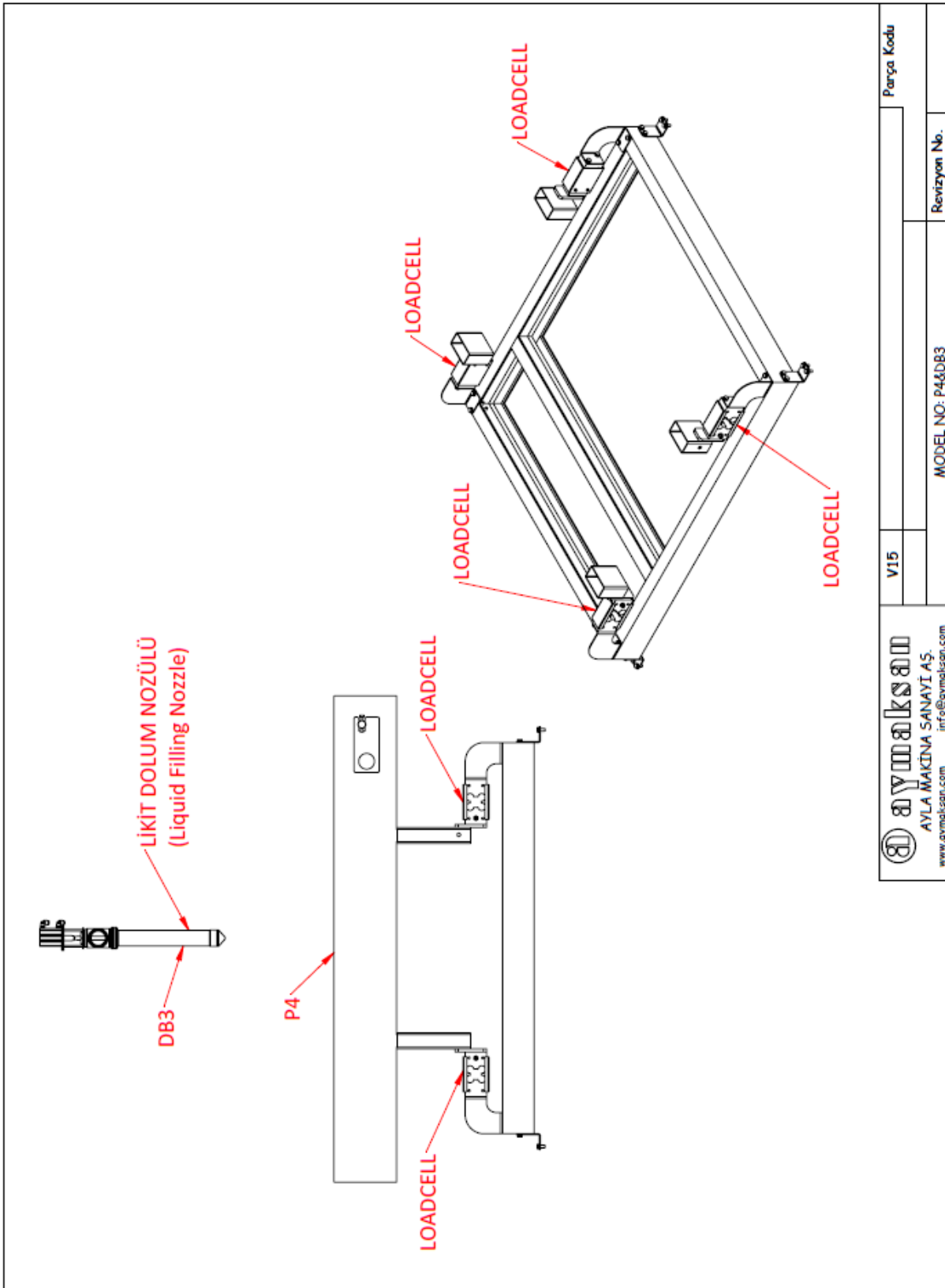

Figure 18. P4_DB3_V15 automatic gravimetric filling instrument.

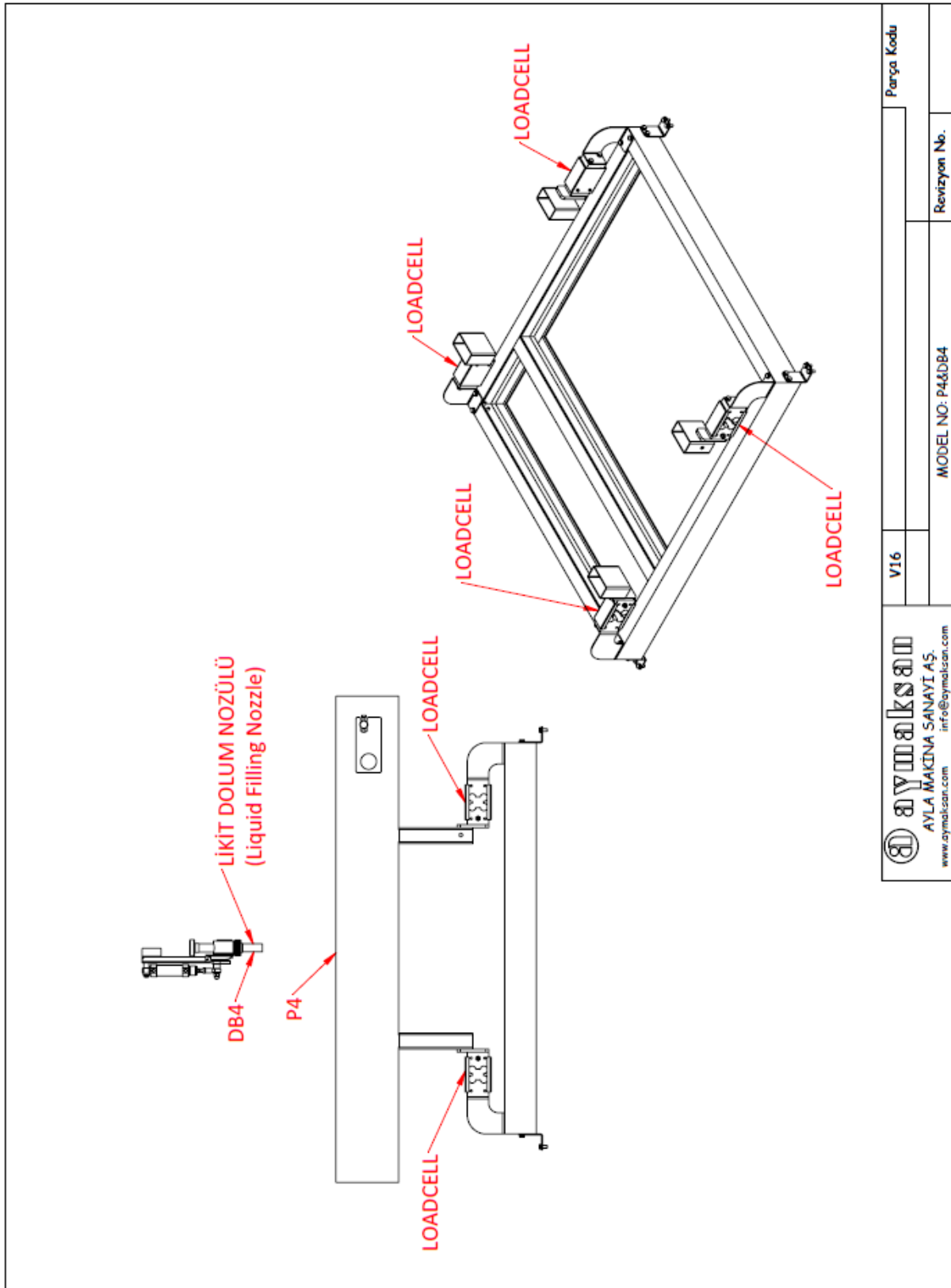

Figure 19. P4_DB4_V16 automatic gravimetric filling instrument.

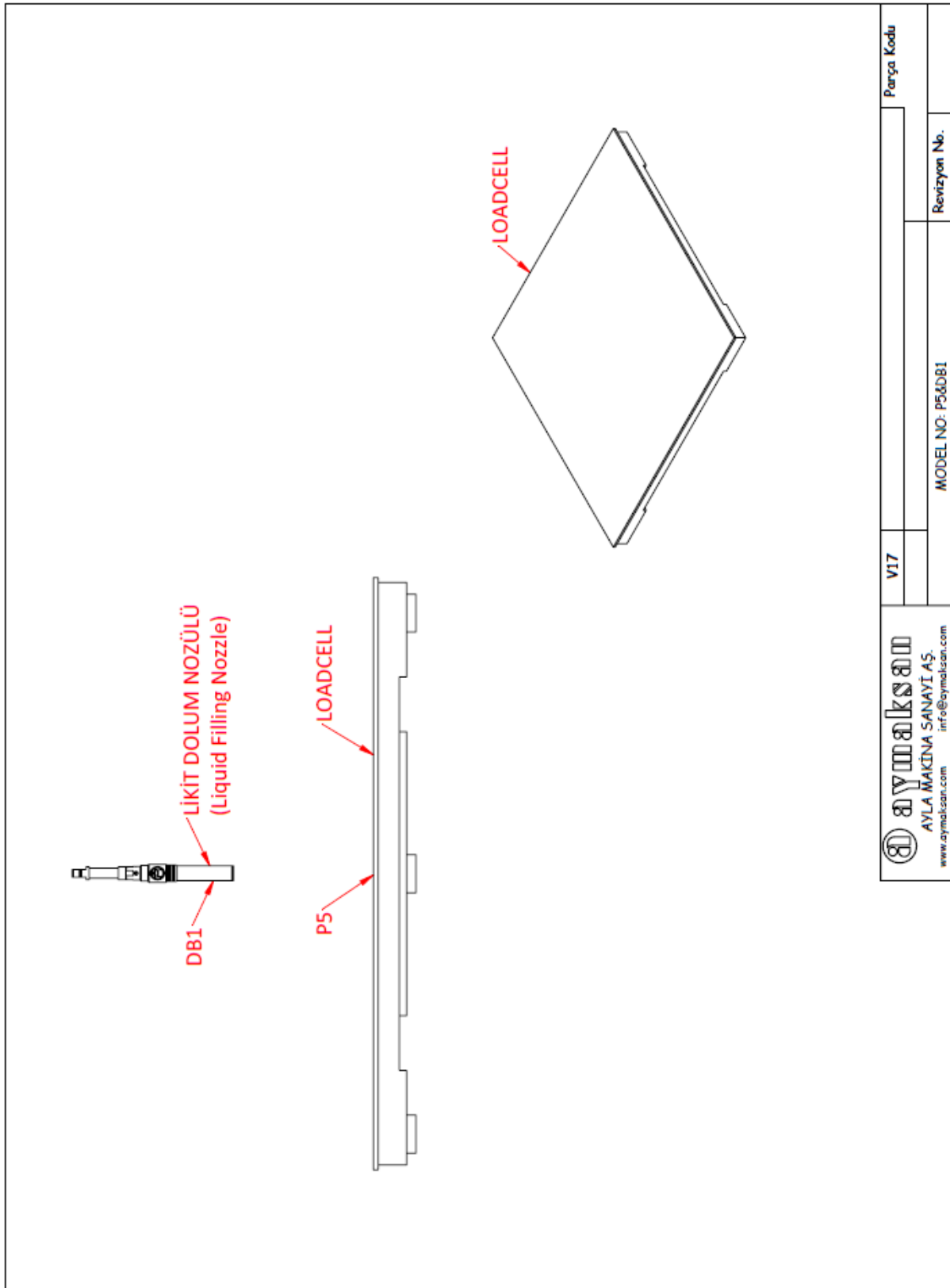



Figure 20. P5_DB1_V17 automatic gravimetric filling instrument.

 AYMAKSAN AYLA MAKINA SANAYI A.Ş. www.aymaksan.com info@aymaksan.com	V17	MODEL NO: P54DB1	Revizyon No.
			Parça Kodu

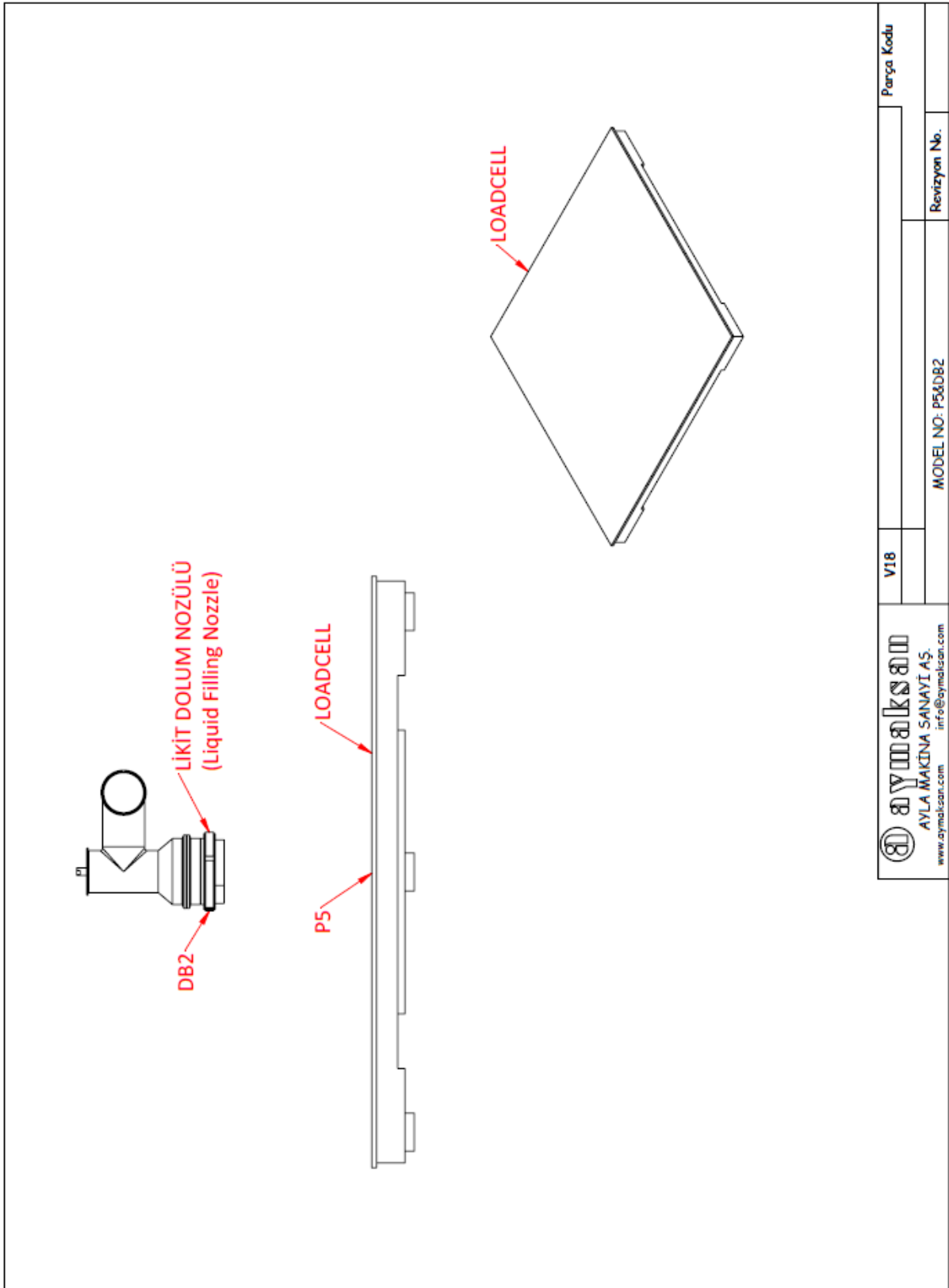

Figure 21. P5_DB2_V18 automatic gravimetric filling instrument.

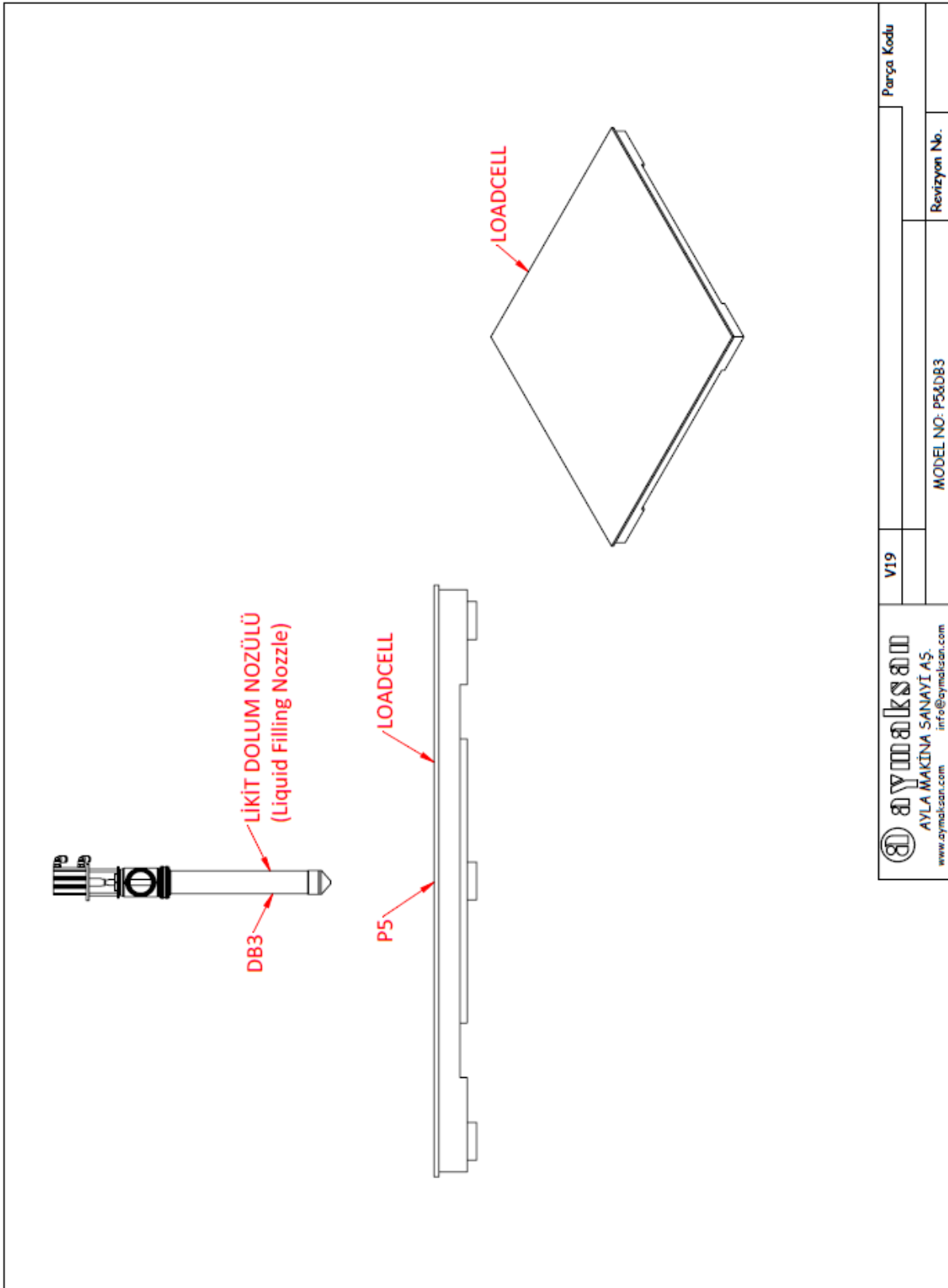

Figure 22. P5_DB3_V19 automatic gravimetric filling instrument.

AYMALKSAN AYLA MAKİNA SANAYİ AŞ. www.aymalcan.com info@aymalcan.com	V19	Parça Kodu
		Revizyon No.
MODEL NO: P5DB3		

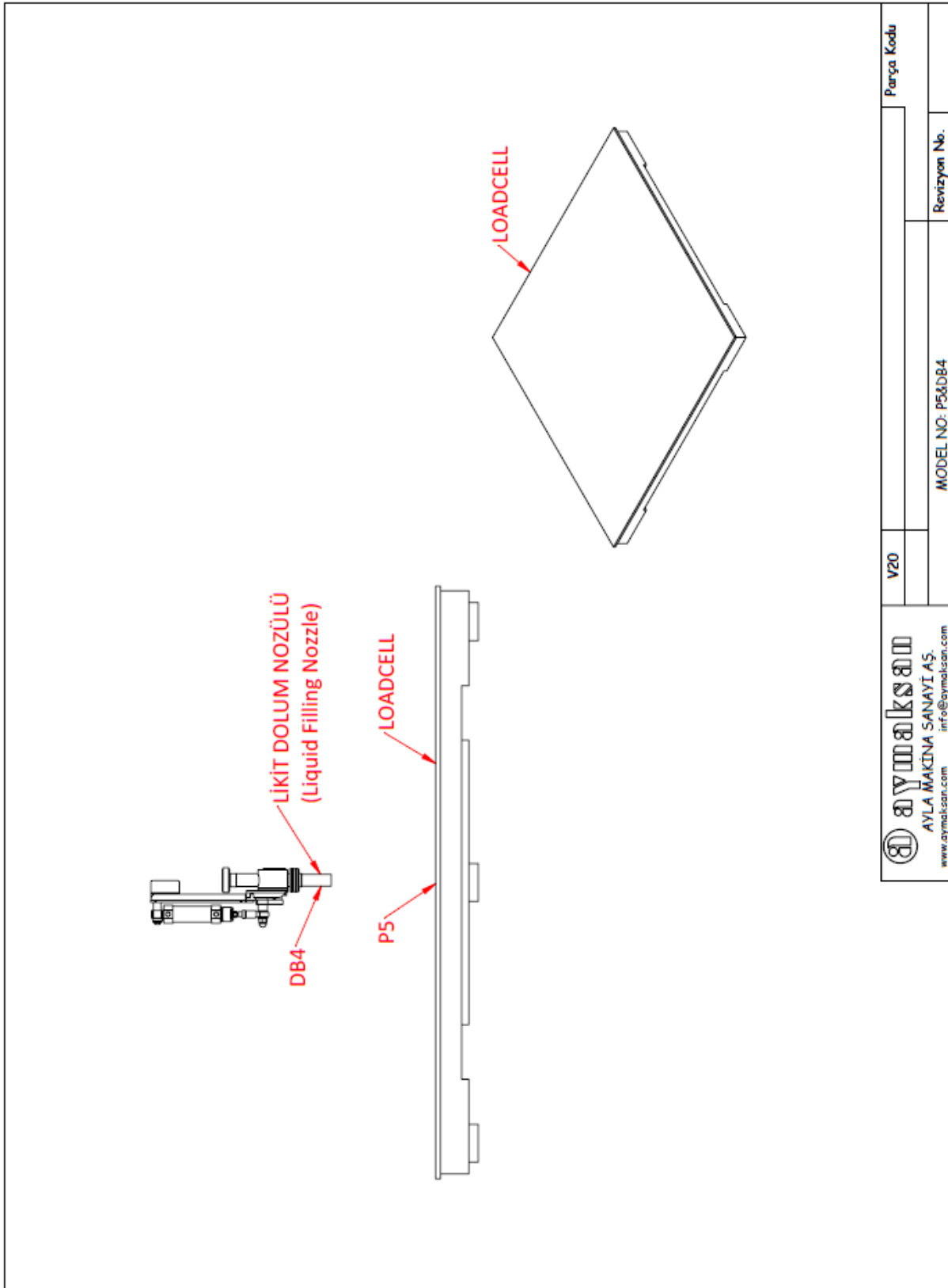

Figure 23. P5_DB4_V20 automatic gravimetric filling instrument.

10. Composition of modules – an example

COMPATIBILITY OF MODULES

Ref.: WELMEC 2

Non-Automatic Weighing Instrument, single-interval.

Certificate of EU Type-Approval N°:

TAC: 0200-MID-11310

INDICATOR

A/D (Module 1)

Type:

ECI

Accuracy class according to EN 45501 and OIML R76:

Class_{ind} (I, II, III or IIII)

III

Maximum number of verification scale intervals (n_{max}):

n_{ind}

10000

Fraction of maximum permissible error (mpe):

p₁

0,5

Load cell excitation voltage:

U_{exc} [Vdc]

10

Minimum input-voltage per verification scale interval:

Δu_{min} [μV]

1

Minimum load cell impedance:

R_{Lmin} [Ω]

35

Coefficient of temperature of the span error:

Es [% / 25°C]

0,0005

Coefficient of resistance for the wires in the J-box cable:

Sx [% / Ω]

0,0048

Specific J-box cable-Length to the junction box for load cells:

(L/A)_{max} [m / mm²]

431

Load cell interface:

6-wire (remote sense)

Additive tare, if available:

T⁺ [% of Max]

0

Initial zero setting range:

IZSR [% of Max]

-10 / 10

Temperature range:

T_{min} / T_{max} [°C]

-10 / 40

Test report (TR), Test Certificate (TC) or OIML Certificate of Conformity:

LOAD RECEPTOR

(Module 2)

Type:

Hopper

Construction:

Fraction of mpe:

p₂

0,5

Number of load cells:

N

3

Reduction ratio of the load transmitting device:

R=F_M / F_L

1

Dead load of load receptor:

DL [% of Max]

70

Non uniform distribution of the load:

NUD [% of Max]

20

Correction factor:

Q = 1 + (DL + T⁺ + IZSR⁺ + NUD) / 100

2

LOAD CELL

ANALOG (Module 3)

Type:

Esit BB

Accuracy class according to OIML R60:

Class_{LC} (A, B, C or D)

C

Maximum number of load cell intervals:

n_{LC}

3000

Fraction of mpe:

p₃

0,7

Rated output (sensitivity):

C [mV / V]

2

Input resistance of single load cell:

R_{LC} [Ω]

350

Minimum load cell verification interval: (v_{min%} = 100 / Y)

v_{min%} [% of E_{max}]

0,005

Rated capacity:

E_{max} [kg]

100

Minimum dead load, relative:

(E_{min} / E_{max}) * 100 [%]

0

Temperature range:

T_{min} / T_{max} [°C]

-10 / 40

Test report (TR) or Test Certificate (TC/OIML) as appropriate:

COMPLETE WEIGHING INSTRUMENT

Single-interval

Manufacturer:

Aymaksan Ayla Makina

Type:

LD 531 / BD 325 LCM AGFI

Accuracy class according to EN 45501 and OIML R76:

Class_{WI} (I, II, III or IIII)

III

Fractions: p_i = p₁² + p₂² + p₃²:

p_i

1,0

Maximum capacity:

Max [kg]

60

Number of verification scale intervals:

n

3000

Verification scale interval:

e [kg]

0,02

Utilisation ratio of the load cell:

α = (Max / E_{max}) * (R / N)

0,20

Input voltage (from the load cells):

Δu = C * U_{exc} * α * 1000 / n [μV/e]

1,33

Cross-section of each wire in the J-box cable:

A [mm²]

0,22

J-box cable-Length:

L [m]

10

Temperature range to be marked on the instrument: Not required

T_{min} / T_{max} [°C]

Peripheral Equipment subject to legal control:

Acceptance criteria for compatibility		Passed, provided no result below is < 0	
Class _{WI}	<= Class _{ind} & Class _{LC} (WELMEC 2: 1)	Class _{WI}	PASSED
p _i	<= 1 (R76: 3.5.4.1)	1 - p _i	0,0
n	<= n _{max} for the class (R76: 3.2)	n _{max} for the class - n	7000
n	<= n _{ind} (WELMEC 2: 4)	n _{ind} - n	7000
n	<= n _{LC} (R76: 4.12.2)	n _{LC} - n	0
E _{min}	<= DL * R / N (WELMEC 2: 6d)	(DL * R / N) - E _{min}	14
v _{min} * √N / R	<= e (R76: 4.12.3)	e - (v _{min} * √N / R)	0,011
or (if v _{min} is not given)		Alternative solutions: ↑ ↓	
(E _{max} / n _{LC}) * (√N / R)	<= e (WELMEC 2: 7)	e - ((E _{max} / n _{LC}) * (√N / R))	
Δu _{min}	<= Δu (WELMEC 2: 8)	Δu - Δu _{min}	0,33
R _{Lmin}	<= R _{LC} / N (WELMEC 2: 9)	(R _{LC} / N) - R _{Lmin}	82
L / A	<= (L / A) _{max} ^{WI} (WELMEC 2: 10)	(L / A) _{max} ^{WI} - (L / A)	1465
T _{range}	<= T _{max} - T _{min} (R76: 3.9.2.2)	(T _{max} - T _{min}) - T _{range}	20
Q * Max * R / N	<= E _{max} (R76: 4.12.1)	E _{max} - (Q * Max * R / N)	60,0

Signature and date:

Conclusion PASSED

This is an authentic document made from the program:
"Compatibility of NAWI-modules version 3.2".