



We help ideas meet the real world

CERTIFICATE of EU TYPE-EXAMINATION

No. DK 0199.137 Revision 1

M2200-P02-HOP-xxxxx

DISCONTINUOUS TOTALIZING AUTOMATIC WEIGHING INSTRUMENT
and / or
AUTOMATIC CATCHWEIGHING INSTRUMENT

Issued by DELTA Danish Electronics, Light & Acoustics
EU - Notified Body No. 0199

In accordance with the requirements for the non-automatic weighing instrument of Directive 2004/22/EC of the European Parliament and Council on Measuring Instruments (MID).

Issued to Marel hf
Austurhraun 9
210 Gardabaer
Iceland

In respect of Automatic weighing instrument designated M2200-P02-HOP-xxxxx with variants of modules of load receptors, load cells and peripheral equipment.
Accuracy class: 0.2, 0.5, 1 or 2, respective Y(a) or Y(b).
Maximum capacity, Max: ≥ 10 kg.
Verification scale interval: $e \geq 10$ g
Maximum number of verification scale intervals: $n \leq 7500$ (however dependent on environment and the composition of the modules).
Variants of modules and conditions for the composition of the modules are set out in the annex.

The conformity with the essential requirements in Annex 1 and the specific requirements in Annex MI-006, chapter I, II & III of the Directive 2004/22/EC is met by the application of OIML R107-1:1997, OIML R51-1:2006, WELMEC Guide 7.2, WELMEC Guide 8.16-1:2006, and WELMEC Guide 8.16-2:2006.

Note: This revised edition replaces the certificate No. DK 0199.137.

The principal characteristics and approval conditions are set out in the descriptive annex to this certificate.

The annex comprises 17 pages.

Issued on 2009-06-03
Valid until 2017-12-19

Signatory: J. Hovgård

DELTA
Danish Electronics,
Light & Acoustics

Venlighedsvej 4
2970 Hørsholm
Denmark

Tel. +45 72 19 40 00
Fax +45 72 19 40 01
www.delta.dk
VAT No. DK 12275110

Descriptive annex

Contents		Page
1.	Name and type of instrument and modules	2
2.	Description of the construction and function	2
2.1	Construction	2
2.2	Function	3
3.	Technical data	4
3.1	M2200-P02-HOP-xxxxx Automatic weighing instrument	4
3.2	Weighing indicator	5
3.3	Load cells	6
3.4	Load receptors	6
3.5	Composition of modules	6
4.	Interfaces and peripheral equipment	7
4.1	Interfaces	7
4.2	Peripheral equipment	8
5.	Approval conditions	8
5.1	Connection of cables	8
5.2	Alibi storage	8
5.3	Compatibility of modules	8
6.	Special conditions for verification	8
6.1	Composition of modules	8
6.2	Data storage device	8
6.3	Integral verification	8
6.4	The material tests of the verification	9
7.	7. Securing and location of seals and verification marks	9
7.1	Securing and sealing	9
7.2	Verification marks	13
8.	Location of CE mark of conformity and inscriptions	13
8.1	Identification plate	13
9.	Pictures	14
10.	Composition of modules - illustrated	17

1. Name and type of instrument and modules

The automatic weighing instrument is designated M2200-P02-HOP-xxxxxx and is intended for statically weighing of loose materials.

The weighing instrument consists of an electronic weighing indicator M2200-P02 and a hopper load receptor.

It can be used as a discontinuous totalising automatic weighing instrument, as an automatic catch weighing instrument, or as both types on the same time. In the latter case the load weighed in the single weighing cycle confirms with OIML R51 and the totalisation of all the weighings in a batch confirms with OIML R107. The instrument carries out tare weighing by first weighing the full hopper and, after emptying, weighing the empty hopper to determine the net mass or the material that passes through the weighing instrument.

A separate control cabinet contains I/O (input / output) electronics and air valves for operating the transport mechanism. It also contains the Mains Switch, Emergency Stop, Start-Stop for automatic operation and visual error indication.

Unless the weighings can be repeated or both parties of the transaction are present, the M2200-P02 shall be configured with M22-DSD internal alibi storage device or be connected to M12-DSD or another certified external alibi storage device.

The Instrument is Type P and Risc Class C with extension T and S according to WELMEC Guide 7.2 (2005).

The modules appear from the sections 3.1, 3.2, 3.3 and 3.4; the principle of the composition of the modules is set out in the sections 6.1 and 10.

2. Description of the construction and function

2.1 Construction

2.1.1 Indicator

The indicator has a watertight stainless steel enclosure consisting of two parts, a bottom part in which the electronics are placed and a top cover fastened by screws through the bottom side of the indicator. The indicator is mounted on a stainless steel wall bracket on which the indicator can be tilted back and forth. A fastening handle on each side is then used for adjusting the tilting. On the front side of the indicator is a clear plastic window through which the primary weight display, rating plate and other display annunciators can be seen. On the right side of the display window is a twelve key keypad, and beneath it are four programmable function keys for operating the indicator.

The front panel comprises:

- A 128 x 240 pixel LCD display with backlight, size 68 x 123 mm (8 x 40, or 320 characters, in the standard font). This display is used for all indication, like the primary weight display, weighing unit indication, STEADY indication, ZERO indication, NET indication and Max, Min, division and range information.
- Ten key numeric keypad (0 to 9).
- A check mark key (enter key).
- A page key for control (rotate between display pages and return from menus).
- Four programmable function keys. One of them functions as a combined TARE and ZERO key along with the primary weight indication.

Supplementary equipment:

- As an option, a special 24 key IR Remote Controller type MR-1 is available.

The bottom side of the indicator:

- Seven cable glands for cables for connecting peripheral equipment, power and load cell.

Electronics

One PCB containing all electronics is mounted to the bottom part of the enclosure. Connection to power, peripheral and load cell cables are via connectors on the bottom edge of the PCB. The keypad connection is in the top-right corner of the PCB.

Legally relevant Firmware is programmed in to a single chip microcontroller which is soldered to the main board. The microcontroller can be re-programmed in the field, but only by using a special software tool.

The microcontroller is programmed via one of the serial interfaces using special software provided by the manufacturer of the microcontroller. This task is only performed by the manufacturer of the Indicator, or his service personnel.

The programming is automatic, but it has to be initiated in a certain way. If not, there is a danger of permanent damage, which would render the Indicator in-operable.

When the Firmware starts up, a checksum test is done to make sure the Firmware is OK.

The power supply of the Indicator is mounted to the back of the PCB. The two power supply options consist of:

- 110 - 230 VAC Mains Power Supply,
- 12 to 24 VDC power supply.

2.1.2 Load cells

Set out in Section 3.3.

2.1.3 Load receptor

Set out in Section 3.4.

2.1.4 Interfaces and peripheral equipment

Set out in Section 4.

2.2 Function

The instrument is a microprocessor based electronic indicator for internal connection to load receptors with strain gauge load cells. Two verified load cell inputs are provided. The weight information appears in a primary weight digital display on the front panel LCD display, and may be transmitted to peripheral equipment.

The operation of the indicator is divided into four parts, the weighing module, the system software, the fixed application program and a downloadable user application program. The operation of the weighing module is always the same. The system has software separation between the fixed application programme and the user application programme. The downloadable user application programme may be downloaded to the P02 versions of the M2200.

The application programmes can take the weighing results and store them in memory, or send data records to a peripheral printer or computer. The interface between the user application programme and other software is defined as protective.

All variants of instruments have the same verified weighing module, regardless of the application or system software. The letters 02 in the type designation M2200-P02 stand for specific system software and a fixed application programme.

The primary weight display is used to display other information than weight during setup and adjustment, and also during display test and during a significant fault. During the display of other information, the weighing mode is inoperative.

The functions provided are detailed below.

2.2.1 Functions and devices

The automatic weighing instrument has the following permitted functions and devices that are subject to the Measuring Instrument Directive:

- Power up test
- Initial zero setting device (max. 20 % of Max)
- Semiautomatic zero setting device
- Zero tracking device
- Automatic zero setting device
- Automatic tare device
- Extended indicating device (service mode only)
- No motion detection and indication
- Gravity compensation
- Detection of significant fault
- M22-DSD internal data storage device (Alibi)
- Transmission of measurement data to an external data storage device (Alibi)

2.2.2 Software identification

The approved firmware version is 3.20-14 or higher.

In order to include the M22-DSD device firmware version shall be 3.70-09 or higher.

3. Technical data

The automatic weighing instruments and its modules are set out as follows:

3.1 M2200-P02-HOP-xxxxx Automatic weighing instrument

Type:	M2200-P02-HOP-xxxxx
Accuracy class:	0.2, 0.5, 1 or 2 for totalizing hopper weigher Y(a) or Y(b) for catchweighing
Maximum capacity (Max):	≥ 10 kg
Minimum capacity (Min):	≥ 200 e
Verification scale interval (e):	$e \geq 0.01$ kg and $e = \text{Max} / n$
Totalization scale interval (d_t):	$= e$
Minimum totalized load (Σ_{\min}):	≥ 1000 e for accuracy class 0.2 ≥ 400 e for accuracy class 0.5 ≥ 200 e for accuracy class 1 ≥ 100 e for accuracy class 2

Weighing range:	Single-interval
Number of Verification Scale Intervals (n):	≤ 7500
Temperature range:	-10° to 40° C
Weighing mode:	Static
Maximum time between automatic zero setting:	20 minutes
Electromagnetic class:	E2
Humidity:	Non-condensing

3.2 Weighing indicator

The M2200-P02 weighing indicator has the following characteristics:

Type:	M2200-P02
Temperature range:	-10° to 40° C
Accuracy class:	III and IIII
Weighing range:	Single-interval, multi-range
Maximum number of verification scale intervals:	$n'_{\max} = 7,500$ (for each range)
Internal resolution:	± 8388608 counts
Maximum tare effect:	-Max
Fractional factor:	$p'i = 0.5$
Excitation voltage:	14 VDC $\pm 5\%$
Minimum input voltage:	0.6 μ V/e according to 2004/22/EC class E2
Sensitivity range:	5 mV/V
Maximum input range:	70 mV
Minimum signal voltage for dead load:	-70 mV
Maximum signal voltage for dead load in case of "additive dead load":	60 mV
Maximum influence of temperature on the zero drift:	0.06 μ V/ $^{\circ}$ C
Maximum influence of temperature on the span drift:	4 ppm/ $^{\circ}$ C
Circuit for remote sense:	Remote sensing using 6-wires in the load cell cable
Optional 4-wire system:	This is allowed if load cell(s) is connected directly to the weighing indicator.
Minimum input impedance:	85 Ohm for load cells
Nominal input impedance:	350 Ohm
Maximum input impedance:	1 kOhm
Maximum line resistance between indicator and load cell:	3 Ohm for each wire in a 6-wire system
Operating temperature range:	Min -10° C, Max $+40^{\circ}$ C
Display and indicators :	LCD; 128 x 240 pixel graphical display (8 x 3 0 characters)
A/D converter:	23 bit Delta-Sigma type converter
Peripheral interfaces:	Set out in section 4
Power requirements:	24 VDC, or 110 - 230 VAC, 0.16 - 0.1A Optional battery operation from a 12 - 24V battery, 0.8 A.
Peripheral interface:	Set out in Section 4

3.2.1 Connecting cable between the indicator and the junction box for load cells

The cable between the weighing indicator and a junction box for load cells shall be a 6-wire system using sense.

3.2.1.1 6-wire system

Line : 6 wires, screened

Option 1:

Maximum length : 90 m / mm² (for n = 7,500)

In case the (n) for the weighing instrument is less than (n) mentioned above, the following apply:

Option 2:

Coefficient of temperature of the span error of the indicator: $E_s = 0.006$ [% / 25K]

Coefficient of resistance for the wires in the J-box cable: $S_x = 0.0132$ [% / ohm]

$L/A_{\max} = 295.86 / S_x * (emp / n - E_s)$ [m / mm²] in which $emp = \pi i * mpe * 100 / e$

From this, the maximum cable length for the weighing instrument may be calculated with regard to (n) for the actual configuration of the instrument.

Reference: See section 10.

The calculation program is obtainable by downloading at www.delta.dk/weighing.

3.3 Load cells

The load receptors are designed for fix mounting.

3.3.1 General acceptance of modules

Any load cell(s) may be used for instruments under this type examination certificate provided the following conditions are met:

- 1) There is a respective test certificate (EN 45501) or an OIML Certificate of Conformity (R60) issued for the load cell by a Notified Body responsible for type examination under the Directive 90/384/EEC.
- 2) The certificate contains the load cell types and the necessary load cell data required for the manufacturer's declaration of compatibility of modules (WELMEC 2, Issue 4, 2004), and any particular installation requirements. A load cell marked NH is allowed only if humidity testing to EN 45501 has been conducted on this load cell.
- 3) The compatibility of load cells and indicator is established by the manufacturer by means of the compatibility of modules form, contained in the above WELMEC 2 document, or the like, at the time of EC verification or declaration of EC conformity of type.
- 4) The load transmission must conform to one of the examples shown in the WELMEC 2.4 Guide for load cells.

3.4 Load receptors

The following type of load receptor is approved for the automatic weighing instrument:

- Hopper scale for static weighing

3.5 Composition of modules

In case of composition of modules, EN 45501 paragraph 3.5 and 4.12 shall be satisfied.

4. Interfaces and peripheral equipment

4.1 Interfaces

The indicator has six peripheral interfaces designated RS232-0, RS232-1, RS232-2, Ethernet, Infra Red and CAN, which allow peripheral equipment to be connected.

All interfaces are characterised "Protective interfaces" according to paragraph 8.4 in the Directive.

The interfaces may be connected to

- a) Non-verified peripheral equipment, not used for legal transactions.
- b) Non-verified peripheral equipment used for legal transactions, if the indicator is also connected to a verified printer, which prints any legal transaction for the purpose of documentation and receipt (tally roll records).
- c) Verified peripheral equipment used for legal transactions.

Declaration concerning protective interfaces

The following applies to the operation of the interfaces of the indicator: It is not possible to interfere with the operation of the weight indicating device. The value of the zero reference cannot be adjusted. The value of the automatic and semi-automatic tare cannot be adjusted.

It is possible to remove the "Protective interface" status of the interfaces by operating a hardware jumper switch. When the T4 (Config Enable) jumper switch is closed (ON or YES) the instrument can be controlled completely through the interfaces. This condition is indicated by slow blinking of the primary weight indication.

The interfaces are set out below:

4.1.1 RS232

RS232-0, RS232-1 and RS232-2 are standard RS232 bidirectional interfaces with the default setting of 9600 Baud, 8 data bits and no parity. The Baud rate can be set to 1200, 2400, 4800, 9600, 19200 or 38400, but the parity or number of data bits cannot be changed.

RS232-0 is normally only used for programming the microcontroller operating the indicator. It is also used by the IrDA infrared interface. It is not possible to use the RS232-0 interface for programming the microcontroller unless the jumper switch T2 (Program) is closed.

4.1.2 Infra Red

Infra Red is a bidirectional infrared interface based on the IrDA physical layer, 9600 Baud, 8 data bits and no parity. Infra Red uses the same serial port as RS232-0.

4.1.3 CAN

CAN is a Controller Area Network interface for bus connection of CAN equipment using a single twisted pair cable (CAN-Bus).

CAN is standardised according to ISO 11898 (Level 1 and 2) and:

CAN Application Layer for Industrial applications CiA DS-201 ... CiA DS-207

CANopen Communication Profile for Industrial Systems CiA Draft Standard DS-301

4.1.4 Ethernet

Ethernet is an IEEE 802.3, 10BASE-T twisted pair interface for connection to standard Ethernet networks via TCP/IP protocol.

4.1.5 Specification of connecting cables

RS232 interface cable is a screened, four-wire, 0.22 to 0.5 mm² (AWG 24 to 20). Combined CAN and power cable is a screened Belden 3084A two twisted pair cable, the power pair is 0.33 mm² or AWG 22 and the data pair is 0.2 mm² or AWG 24. The Ethernet cable is a standard 10BASE-T shielded, CAT 5, multi strand cable.

4.2 Peripheral equipment

Connection between the indicator and peripheral equipment is allowed by screened cable.

The instrument may be connected to any simple peripheral device (e.g. a printer) with a CE mark of conformity.

5. Approval conditions

5.1 Connection of cables

All cables shall be shielded, and the shield shall be properly EMC wise connected to the housing / connector in both ends.

5.2 Alibi storage

M2200 may as an alternative to internal alibi storage type M22-DSD use an external alibi storage type: M12-DSD, Test Certificate: DK0199-Alibi-07.01.

5.3 Compatibility of modules

In case of composition of modules, WELMEC 2 (Issue 4) 2004, paragraph 11 shall be satisfied.

6. Special conditions for verification

6.1 Composition of modules

The environmental conditions should be taken into consideration by the composition of modules for a complete weighing instrument, for example instruments with load receptors placed outdoors and having no special protection against the weather.

The composition of modules shall agree with Section 5.3.

An example of a declaration of conformity document is shown in Section 10.

6.2 Data storage device

When the automatic weighing instrument is used for applications that can be regarded as non-repeatable, the M2200-P02 shall either be configured with M22-DSD internal alibi storage device or be connected to M12-DSD or another certified external alibi storage device with an evaluation/test certificate from a notified body for type examination of weighing instruments under Directive 2004/22/EC.

6.3 Integral verification

The automatic weighing instrument can be used for integral verification as it can be set up to have interruption of the automatic operation with pre-discharge (gross) interrupt and post-discharge (tare) interrupt.

6.4 The material tests of the verification

6.4.1 Discontinuous totalising

The procedure in OIML R107-1:1997 section 5.2.1.2 can be followed as it is.

6.4.2 Catch weighing

As loose materials especially in the food industry is not suitable for repeatable weighings, the value for each of the four test loads (OIML R51-1:2006, section A.5.1.1 (2)) shall be used as a set point for the filling of the hopper. The automatic catchweigher shall run for at least 10 weighing cycles and for each weighing cycle the error shall be determined as the difference between the indicated automatic weighing result and the mass determined by integral verification.

6.4.3 Discontinuous totalizing and Catch weighing

The verification of the instrument as automatic catchweigher shall be performed according to the above section 6.4.2. For these four tests the totalised weight and the masses determined by integral verification shall be used as part of the weighings prescribed in the above section 6.4.1, normally only leaving one additional material test at close to minimum totalised load (Σ_{\min}) to be performed.

7. 7. Securing and location of seals and verification marks

7.1 Securing and sealing

Seals shall bear the verification mark of a notified body according to ANNEX F of the Directive 2004/22/EC or alternative mark of the manufacturer according to ANNEX D of the Directive 2004/22/EC.

7.1.1 Mechanical sealing

The identification plate shall be secured against removal with a brittle plastic sticker.

7.1.2 Indicator sealing

There are two separate means of sealing the instrument and either of them can be used as preferred. The two sealing options are:

- Two event counters, CAL and CON.
- External wire and plumb seal along with an internal jumper switch.

7.1.2.1 Event Counters, CAL and CON

The indicator is sealed by two event counters which are incremented each time the calibration or sealed configuration parameters are changed. The maximum count of both event counters is 999, starting from 001. The event counters are displayed during start-up for about five seconds and are identified as; CALxxx and CONxxx, where xxx is the count. The CAL counter seals the adjustment parameters and the CON counter the configuration settings. A further protection is provided by a password for restricting access to the calibration and configuration.

The indicator is always sealed when it starts up after power-down or reset, or after adjustment to sealed parameters. A new adjustment will increment the respective counter. The indicator has remote configuration capability through the interfaces. This feature is enabled using an internal jumper switch (T4, Config Enable). If remote configuration is enabled, the primary weight indication will blink. Remote adjustments through interfaces will increment the counters.

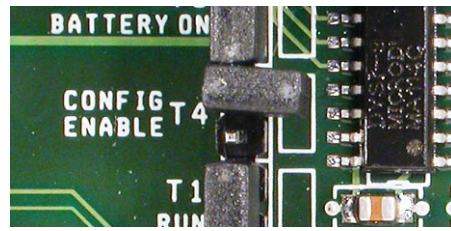

“Remote Configuration Enable” jumper switch, default OPEN or NO (off)

To indicate the sealed status of the event counter, a label with the inscribed count of the event counter is placed either on the bottom or the left side of the indicator. This label also bears the additional designation “EVENT COUNTERS” for identification. The label is made of material which will self-destruct when removed. The inscribed event count is either permanently printed or handwritten by a felt tipped pen using permanent ink. All three digits of the event counters are to be written, and pre- and suffixed by a hyphen. The orientation shall be the same as of the “EVENT COUNTERS” identification.

Example:

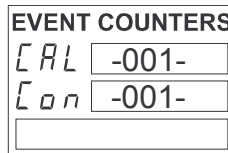

Event counter label

The EVENT COUNTER's label is sealed by partially covering it with an official sealing label.

Legal authorities can use their own means of affixing and inscribing the sealed count of the event counter, or documenting the count for later confirmation of the sealing status.

If sealing of the access to the interior of the indicator is wanted, it can be done by affixing a sealing label across the junction between the upper and lower part of the enclosure.

The status of the event counters can be displayed by pressing the PAGE key for about three seconds. The top menu of the instrument is then displayed.

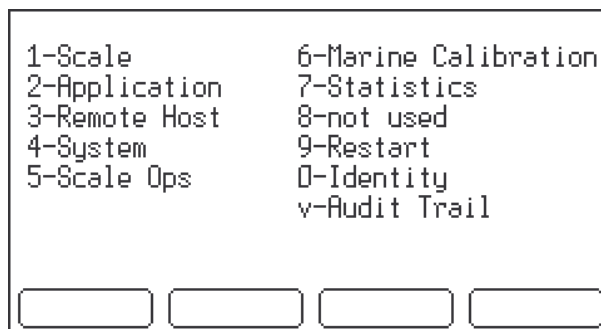

By pressing the CHECK key, audit trail (event counter) information will be displayed.

CAL Events	2
CON Events	4
Program Jumper	No
Config Enable Jumper	No
Lock Enable Jumper	No
Seal Enable Jumper	No
M22-DSD option	Yes

See the following text for an explanation of the Lock and Seal Enable Jumpers. See chapter 4.1 “Interfaces” for an explanation of the Config Enable Jumper.

The following parameters are protected using the **CAL** event counter:

38 Units	kg
40 AD at Zero	1929425
41 AD at Load	2242029
44 Span	1.766958e-06
132 Gravity Factor	1.000000
155 Using Load Cell 2 only	No
185 Marine weighing	No

The following parameters are protected using the **CON** event counter (parameters 78, 108 and 110 can be either sealed or not, depending on the setup):

CON always sealed:	
80 Max1	3.000kg
81 e1	0.001kg
89 Max2	15.000kg
90 e2	0.002kg
112 Initial zero at startup	Yes
159 Direct Sale to Public	No
165 Seal Extra Resolution	No
166 Seal Zero Tracking	No
167 Seal Response	No
177 Weighing Module	101
179 Allow remote Zero and Tare	No
297 Blank display below zero	No
298 Remove tare entering first range	No
482 Allow variable display units	Yes
492 Prevent application update	No
896 Allow non-metric display units	Yes
909 Use external alibi server	No
963 Use OIML catchweighing (R51)	Yes
964 Use OIML totalizing (R51 & R107)	No
965 Minimum weight	0.100kg
966 Minimum totalized weight	1.000kg
974 Maximum loads per minute	4.000
986 Warmup time (s)	9
997 Max age of zero (s)	600
1000 Number of stable readings required	1
1004 Use combined zero and tare button	No
1007 Import enabled	No
1008 Export enabled	Yes
1015 Source Device Number	0000000000000000
1021 Pause before recording (s)	0.000
1022 Pause before taking zero (s)	0.000
1033 Use internal alibi server	Yes
1056 Multi-interval (unapproved)	Yes
1062 Dynamic weighing allowed	Yes
CON sealed in some markets (us/canada):	
78 Response	Fast
108 Zero Tracking	Yes
110 Extra Resolution	No
1023 Selective damping allowed	No
1024 Period of selective damping (s)	2.000
1025 Degree of selective damping (n)	3
1026 Spread of selective damping (%)	15.000
1061 Dynamic zero tracker gain	0.050

7.1.2.2 External wire and a plumb seal

An internal jumper switch, T9 or Seal Enable, will make it impossible to change the configuration of the instrument. The indicator can then be sealed by a wire and a plumb seal through holes where the top cover meets the bottom part on the left and rear side of the indicator.

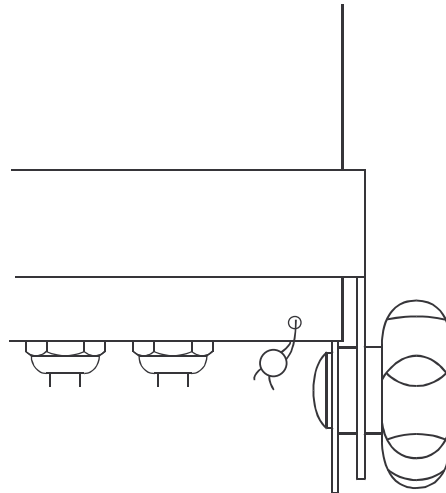

Wire and plumb seal

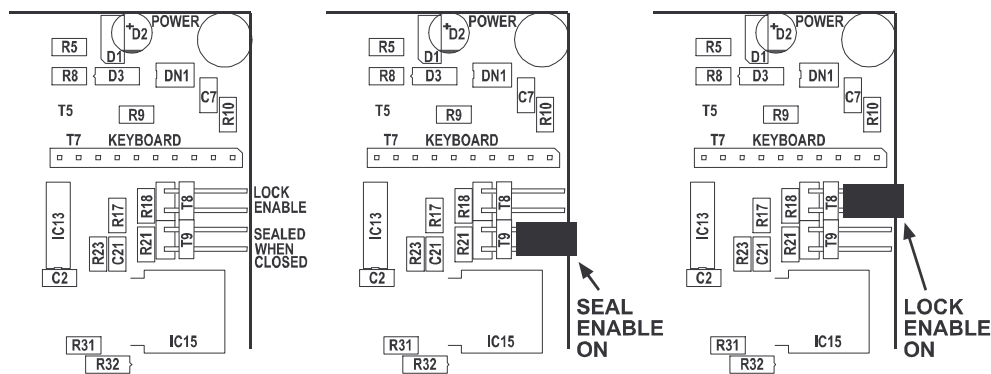

Seal Enable and Lock Enable jumper switches

Seal Enable: When the Seal Enable jumper is ON (contacts closed), the essential parameters and adjustment of the instrument cannot be changed and the indicator can be sealed using a wire and a plumb seal.

Lock Enable: When the Lock Enable jumper is ON (contacts closed), the Service Password can be changed. The Service Password is needed to access the essential parameters and the adjustment of the instrument. The default Service Password is 62735 (as the text “MAREL” mapped on the keypad of a GSM phone). When the Lock Enable is ON, the password can be changed to a more secure one, or it can be cleared for easier access.

W&M Config Password: For further protection against accidental breaking of the Event Counter Seal, a password must be entered before the Weighing Configuration can be changed. The password is 322225.

7.1.3 Junction box for load cells

Access to the junction box, if any, is prevented by means of sealing by plastic stickers or lead seals.

7.2 Verification marks

A sticker with verification marks is to be placed on or near the identification plate of the instrument.

8. Location of CE mark of conformity and inscriptions

8.1 Identification plate

All inscriptions for the instrument shall be placed on the identification plate, which is located on a visible place on the measuring instrument.

8.1.1 CE mark

A sticker with the CE mark of conformity and the supplementary metrology marking consisting of the capital letter 'M' and the last two digits of the year of its affixing, surrounded by a rectangle, shall be located on the identification plate.

8.1.2 Inscriptions

The identification plate shall bear the following inscriptions:

- Manufacturer's trademark and / or name
- Type designation
- Serial number
- Max, Min and e (these shall additional be duplicated near the display)
- Temperature range: -10 / +40 °C
- Electromagnetic class: E2
- Humidity: Non-condensing
- Type examination certificate number

9. Pictures



Figure 1 M2200 indicator

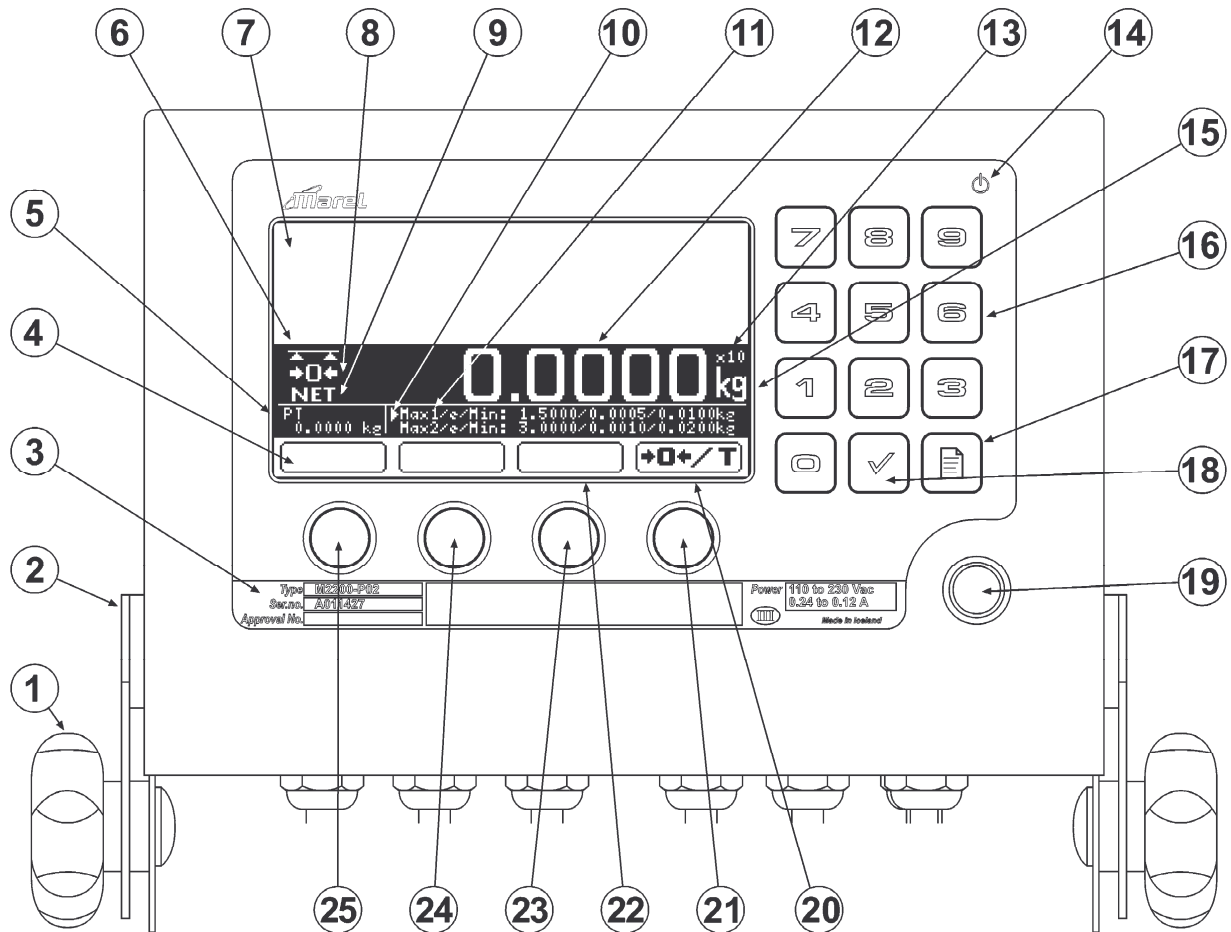

Figure 2 The M2200 Indicator, front view

- | | |
|--|------------------------------------|
| 1. Fastening knob | 14. Power ON indicator |
| 2. Adjustable wall bracket | 15. Weighing unit indicator |
| 3. Rating plate | 16. Numeric keypad, 0 to 9 |
| 4. LCD; push-button legend area | 17. The Page key |
| 5. "PT" Preset Tare indicator and value | 18. The Check key |
| 6. "STEADY" indicator | 19. iButton reader pin |
| 7. LCD; application area | 20. "ZERO/TARE" push-button legend |
| 8. "ZERO" indicator | 21. "ZERO/TARE" push-button |
| 9. "NET" indicator | 22. LCD; push-button legend area |
| 10. Weighing range marker | 23. General purpose push-button |
| 11. Weighing range characteristics | 24. General purpose push-button |
| 12. Primary weight indicator | 25. General purpose push-button |
| 13. Times ten extended weight resolution | |



Figure 3 M2200-P02-HOP-xxxxx with 60 kg hopper load receptor.

10. Composition of modules - illustrated

COMPATIBILITY OF MODULES

Ref.: WELMEC 2

Non-Automatic Weighing Instrument, single-interval

Certificate of EU Type-Approval N°:

TAC: DK0199.137

INDICATOR	A/D (Module 1)	Type: M2200-P02	
Accuracy class according to EN 45501 and OIML R76:	Class _{ind} (I, II, III or IIII)		III
Maximum number of verification scale intervals (n _{max}):	n _{ind}		7500
Fraction of maximum permissible error (mpe):	p ₁		0,5
Load cell excitation voltage:	U _{exc} [Vdc]		14
Minimum input-voltage per verification scale interval:	ΔU _{min} [μV]		0,6
Minimum load cell impedance:	R _{Lmin} [Ω]		85
Coefficient of temperature of the span error:	Es [% / 25°C]		0,006
Coefficient of resistance for the wires in the J-box cable:	Sx [% / Ω]		0,0132
Specific J-box cable-Length to the junction box for load cells:	(L/A) _{max} [m / mm ²]		90
Load cell interface:	6-wire (remote sense)		
Additive tare, if available:	T ⁺ [% of Max]		0
Initial zero setting range:	IZSR [% of Max]	-10 /	10
Temperature range:	T _{min} / T _{max} [°C]	-10 /	40
Test report (TR), Test Certificate (TC) or OIML Certificate of Conformity:			

LOAD RECEPTOR	(Module 2)	Type:	Platform
Construction:			
Fraction of mpe:	p ₂		0,5
Number of load cells:	N		2
Reduction ratio of the load transmitting device:	R=F _M / F _L		1
Dead load of load receptor:	DL [% of Max]		30
Non uniform distribution of the load:	NUD [% of Max]		20
Correction factor:	Q = 1 + (DL + T ⁺ + IZSR ⁺ + NUD) / 100		1,6

LOAD CELL	ANALOG (Module 3)	Type: Vishay TedeA Model 151C	
Accuracy class according to OIML R60:	Class _{LC} (A, B, C or D)		C
Maximum number of load cell intervals:	n _{LC}		3000
Fraction of mpe:	p ₃		0,7
Rated output (sensitivity):	C [mV / V]		2
Input resistance of single load cell:	R _{LC} [Ω]		380
Minimum load cell verification interval: (v _{min%} = 100 / Y)	v _{min%} [% of E _{max}]		0,00833
Rated capacity:	E _{max} [kg]		100
Minimum dead load, relative:	(E _{min} / E _{max}) * 100 [%]		0
Temperature range:	T _{min} / T _{max} [°C]	-10 /	40
Test report (TR) or Test Certificate (TC/OIML) as appropriate:		D09-97.01	

COMPLETE WEIGHING INSTRUMENT

Single-interval:

Manufacturer:		Type: GMB VT300 with platform	
Accuracy class according to EN 45501 and OIML R76:	Class _{WI} (I, II, III or IIII)		III
Fractions: p _i = p ₁ ² + p ₂ ² + p ₃ ² :	p _i		1,0
Maximum capacity:	Max [kg]		60
Number of verification scale intervals:	n		3000
Verification scale interval:	e [kg]		0,02
Utilisation ratio of the load cell:	α = (Max / E _{max}) * (R / N)		0,30
Input voltage (from the load cells):	Δ _v = C * U _{exc} * α * 1000 / n [μV/e]		2,80
Cross-section of each wire in the J-box cable:	A [mm ²]		0,22
J-box cable-Length:	L [m]		1
Temperature range to be marked on the instrument:	Not required	T _{min} / T _{max} [°C]	
Peripheral Equipment subject to legal control:			

Acceptance criteria for compatibility		Passed, provided no result below is < 0	
Class _{WI}	<= Class _{ind} & Class _{LC} (WELMEC 2: 1)	Class _{WI}	PASSED
pi	<= 1 (R76: 3.5.4.1)	1 - pi =	0,0
n	<= n _{max} for the class (R76: 3.2)	n _{max} for the class - n =	7000
n	<= n _{ind} (WELMEC 2: 4)	n _{ind} - n =	4500
n	<= n _{LC} (R76: 4.12.2)	n _{LC} - n =	0
E _{min}	<= DL * R / N (WELMEC 2: 6d)	(DL * R / N) - E _{min} =	9
v _{min} * √N / R	<= e (R76: 4.12.3)	e - (v _{min} * √N / R) =	0,008
or (if v _{min} is not given)		Alternative solutions: ↑ ↓	
(E _{max} / n _{LC}) * (√N / R)	<= e (WELMEC 2: 7)	e - ((E _{max} / n _{LC}) * (√N / R)) =	2,20
ΔU _{min}	<= Δu (WELMEC 2: 8)	Δu - ΔU _{min} =	105
R _{Lmin}	<= R _{LC} / N (WELMEC 2: 9)	(R _{LC} / N) - R _{Lmin} =	421
L / A	<= (L / A) _{max} ^{WI} (WELMEC 2: 10)	(L / A) _{max} ^{WI} - (L / A) =	20
T _{range}	<= T _{max} - T _{min} (R76: 3.9.2.2)	(T _{max} - T _{min}) - T _{range} =	52,0
Q * Max * R / N	<= E _{max} (R76: 4.12.1)	E _{max} - (Q * Max * R / N) =	

Signature and date:

Conclusion PASSED

This is an authentic document made from the program:
 "Compatibility of NAWI-modules version 3.2".

