



We help ideas meet the real world

EC Type Examination Certificate

DK0199.356 Revision 1

23YY

AUTOMATIC GRAVIMETRIC FILLING INSTRUMENT

Issued by DELTA Danish Electronics, Light & Acoustics
EU - Notified Body No. 0199

In accordance with the requirements for the automatic weighing instruments in Directive 2004/22/EC of the European Parliament and Council of March 31, 2004 on Measuring Instruments (MID).

Issued to Bernhard Upmann Verpackungsmaschinen GmbH & Co. KG
Burgsteinfurter Damm 185
D-48432 Rheine-Mesum
Germany

In respect of An automatic gravimetric filling instrument designated **23YY** working as a selective combination weigher with variants of modules of load receptors, load cells, and peripheral equipment.
Reference accuracy class 1
Maximum capacity for each weighing unit, $\text{Max} = n \times d_{\text{load}}$
Verification scale interval for the filling instrument: $d = 5 \text{ g}$
Verification scale interval for the weighing units: $d_{\text{load}} = 2 \text{ g}$, or $d_{\text{load}} = 5 \text{ g}$
Number of verification scale intervals: $n \leq 3000$ as single-interval
(however, dependent on environment and the composition of the modules)
Variants of modules and conditions for the composition of the modules are set out in the annex.

The conformity with the essential requirements in Annex 1 and the specific requirements in Annex MI-006, chapter I & III of the Directive 2004/22/EC is met by the application of OIML R61-1:2004, section 12 & 13 of OIML D11:2004, WELMEC Guide 7.2:2011, and WELMEC Guide 8.16-2:2006.

Note: This certificate is a revised edition which replaces previous revisions.

The principal characteristics and approval conditions are set out in the descriptive annex to this certificate.

The annex comprises 11 pages.

Issued on 2013-01-17
Valid until 2022-06-26

Signatory: J. Hovgård

DELTA
Venlighedsvej 4
2970 Hørsholm
Denmark

Tel. (+45) 72 19 40 00
Fax (+45) 72 19 40 01
www.delta.dk
VAT No. DK 12275110

Descriptive annex

Contents	Page
1. Name and type of instrument and modules	2
2. Description of the construction and function	2
2.1 Construction	2
2.2 Functions	3
3. Technical data	4
3.1 23YY automatic gravimetric filling instrument	4
3.2 LDM 88.1	4
3.3 XV-100	4
3.4 Load cells	5
3.5 Load receptors	5
3.6 Composition of modules	5
3.7 Documents	5
4. Interfaces and peripheral equipment	6
4.1 Interfaces	6
4.2 Peripheral equipment	6
5. Approval conditions	6
5.1 Tolerances for preset target	6
5.2 Compatibility of modules	6
6. Special conditions for verification	6
6.1 Composition of modules	6
7. Securing and location of seals and verification marks	7
7.1 Securing and sealing	7
7.2 Verification marks	7
8. Location of CE mark of conformity and inscriptions	7
8.1 Identification plate	7
9. Pictures	9

1. Name and type of instrument and modules

The automatic gravimetric filling instrument designated 23YY is an associative (selective combination) weigher manufactured by Bernhard Upmann Verpackungsmaschinen GmbH & Co. KG.

The machine is made for weighing food and non-food materials with particle weight of more than 10 g, like potatoes, onions, carrots etc.

The automatic gravimetric filling instrument is available in various models indicated in the name as follows,

23YY

YY : number of individual weighing units.

Approved values: 7, 9, 11, 13 or 15

The name of the instruments may be followed by alphanumeric characters for technical, legal or commercial characterisation of the instrument.

The instrument is a self-indicating filling instrument with single-interval and can be connected to peripheral equipment such as printers or other devices, as appropriate.

The modules appear from Sections 3.1, 3.2, and 3.3; the principle of the composition of the modules is set out in Sections 6.1.

2. Description of the construction and function

2.1 Construction

2.1.1 Controller of filling machine

The filling machine is controlled by a XV-100 PLC. The XV-100 has a built-in graphic display with touch screen used for the operator interface of the machine. All the software of the PLC are stored on a SD-Card

The PLC uses CAN-bus for communication with a number of load cell digitizing module – one for each scale

2.1.2 Load cell digitizing module

Each scale of the filling machine has a LDM 88.1 load cell digitizing module from Hauch & Bach. LDM 88.1 converts the load cell signal to a digital weighing result and uses a CAN-bus module – common for all LDM 88.1s - for communicating with the controller.

Evaluation certificate DK0199-R61-10.01 is issued for LDM 88.1 as a load cell digitizing module for automatic gravimetric filling machines.

2.1.3 Load cells

Set out in Section 3.3.

2.1.4 Load receptor

Set out in Section 3.4.

2.1.5 Interfaces and peripheral equipment

Set out in Section 4.

2.2 Functions

2.2.1 Functions and devices

The automatic weighing instrument has the following permitted functions and devices that are subject to the Measurement Instrument Directive.

- Initial zero setting device (max. 20 % of Max)
- Combined semi-automatic zero-setting and subtractive tare balancing device
- Automatic zero-setting device
- Target (Preset) value device

2.2.2 Software

The software version of the weighing controller is displayed at start-up.

The format for the software version is v.ss, where v is the version number and ss is a sub-revision number for software changes not related to the legal functionality of the software.

The examined software version is 2.05.

3. Technical data

The automatic weighing instruments and its modules are set out as follows:

3.1 23YY automatic gravimetric filling instrument

Type:	23YY
Number of individual weighing units:	7, 9, 11, 13 or 15
Reference class:	1
Accuracy class:	1
Maximum fill (MaxFill):	≤ 27kg
Rated minimum fill (MinFill):	1000 g
Number of loads per fill:	9 (average of 3 to 15 loads)
Maximum capacity (Max):	3000 g
Minimum capacity (Min):	1/9 of Minfill
Verification scale interval (d):	5 g
Verification scale interval for weighing units (d_{load}):	2 g or 5 g
Weighing range:	Single-interval
Number of Verification Scale Intervals (n):	$n = \text{Max} / d_{load}$
Maximum tare effect:	≤ 100 % of Max
Extra warm-up time:	4 minutes
Temperature range:	-10° to +40° C
Electromagnetic class:	E2
Humidity:	Non-condensing
Maximum time between automatic tares:	15 minutes
Mains power supply:	3 x 400 VAC, 50 Hz 60 Hz Hz or 3 x 230 VAC, 50 Hz 60 Hz
Peripheral interface:	Set out in Section 4

3.2 LDM 88.1

Excitation voltage:	5 VDC
Analogue range:	-11 to 11 mV
Minimum input voltage per verification scale interval (Δu_{min}):	1 μV for $d_{load} = 2 \text{ g}$ 2.5 μV for $d_{load} = 5 \text{ g}$
Minimum input impedance:	87.5 ohm
Maximum input impedance:	1200 ohm
Supply voltage:	12 – 24 VDC

3.3 XV-100

The controller of the filling machine has the following characteristics:

Type	XV-1xx-.....
Display:	Graphic TFT color display
Operator input:	Touch screen
Power supply:	24 VDC

3.4 Load cells

All load cells of a 23YY filling machine are identical.

3.4.1 Load cells

The load cell, which is listed below, is certified as a module in the weighing instrument.

Manufacturer	Load cell type	Capacity	Vmin
Tedea-Huntleigh	1040 C3	20 kg	≤ 2 g
Tedea-Huntleigh	355 C3	20 kg	≤ 2 g

3.4.2 General acceptance of load cells

Any load cell(s) may be used for instruments under this certificate of type approval provided the following conditions are met:

- 1) A test certificate (EN 45501) or a respective OIML Certificate of Conformity (R60) is issued for the load cell by a Notified Body responsible for type examination under the Directive 90/384/EEC.
- 2) The certificate contains the load cell types and the necessary load cell data required for the manufacturer's declaration of compatibility of modules (WELMEC 2, Issue 5, 2009), and any particular installation requirements). A load cell marked NH is allowed only if humidity testing to EN 45501 has been conducted on this load cell.
- 3) The compatibility of load cells and indicator is established by the manufacturer by means of the compatibility of modules form, contained in the above WELMEC 2 document, or the like, at the time of EC verification or declaration of EC conformity of type.
- 4) The load transmission must conform to one of the examples shown in the WELMEC 2.4 Guide for load cells.

3.5 Load receptors

Each weighing unit of the automatic weighing instrument has a hopper load receptor.

Construction in brief	Stain-less steel
Reduction ratio	1
Number of load cells	1
Junction box	None
Load cells	According to Section 3.4.1 or Section 3.4.2
Drawings	Various

3.6 Composition of modules

In case of composition of modules, EN 45501 paragraph 3.5 and 4.12 shall be satisfied.

3.7 Documents

The documents filed at DELTA (reference No. T22849) are valid for the weighing instruments described here.

4. Interfaces and peripheral equipment

4.1 Interfaces

One or more of the following interfaces may be incorporated. The interfaces are protective and need not to be secured.

- RS232
- Ethernet

4.2 Peripheral equipment

Connection between the XV-100 and peripheral equipment shall be done by screened cables.

The instrument may be connected to any simple peripheral device with a CE mark of conformity.

5. Approval conditions

5.1 Tolerances for preset target

It is the responsibility of the instrument owner that the in-service tolerance for the instrument is not exceeded. This includes the instrument owner's, or the by him selected user's, setting of tolerances for preset target.

5.2 Compatibility of modules

In case of composition of modules, WELMEC 2 (Issue 5) 2009, paragraph 11 shall be satisfied.

6. Special conditions for verification

6.1 Composition of modules

The composition of modules shall agree with Section 5.2.

7. Securing and location of seals and verification marks

7.1 Securing and sealing

Seals shall bear the verification mark of a notified body according to ANNEX F of the Directive 2004/22/EC or alternative mark of the manufacturer according to ANNEX D of the Directive 2004/22/EC.

7.1.1 Controller of filling machine

7.1.1.1 Sealing of software and set-up data

The software and set-up data are stored on a SD-Card, which is inserted into a slot in the XV-100. The cover plate of the slot shall be sealed with a brittle sticker to prevent exchange of the card.

7.1.2 LDM 88.1

7.1.2.1 Securing of LDM 88.1 set-up

The calibration and configuration parameters are secured by a non-resettable event counter. The current values of the event counter of all LDM 88.1 can be displayed upon request.

To indicate the sealed status of the event counter, the inscribed count of the event counter is written on a label placed on the inscription plate or next to it.

The event counter's label is sealed by partially covering it with an official sealing label.

7.1.2.2 Sealing of LDM 88.1 modules and connections

The LDM 88.1s and their load cell connectors are covered by a transparent plate. The screws holding the plate shall be covered by brittle plastic stickers.

7.1.3 Peripheral interfaces

All peripheral interfaces are "protective". They neither allow manipulation with weighing data or legal setup, nor change of the performance of the weighing instrument in any way that would alter the legality of the weighing.

7.2 Verification marks

A metrological M-sticker and a sticker with verification mark are to be placed on the identification plate of the instrument.

8. Location of CE mark of conformity and inscriptions

8.1 Identification plate

All inscriptions for the instrument shall be placed on the identification plate, which shall be located on a visible place on the instrument.

8.1.1 CE mark and metrological M

A CE mark of conformity and year of production grouped together with space for the metrological M shall be located on the identification plate.

8.1.2 Inscriptions

The identification plate shall bear the following inscriptions:

- Manufacturer's trademark and / or name
- Type designation
- Serial number
- Reference accuracy class Ref(1)
- Accuracy class X(1)
- Type examination certificate number
- Maximum fill (MaxFill =)
- Minimum fill (Minfill =)
- Maximum capacity (Max =)
- Minimum capacity (Min =)
- Verification scale interval (d =)
- Average number of loads/fill
- Maximum rate of operation
- Temperature range: -10 / +40 °C
- Electromagnetic class: E2
- Humidity: Non-condensing
- Supply voltage
- Pneumatic pressure
- Event counter values for each LDM 88.1 module

9. Pictures



Figure 1: 2309.

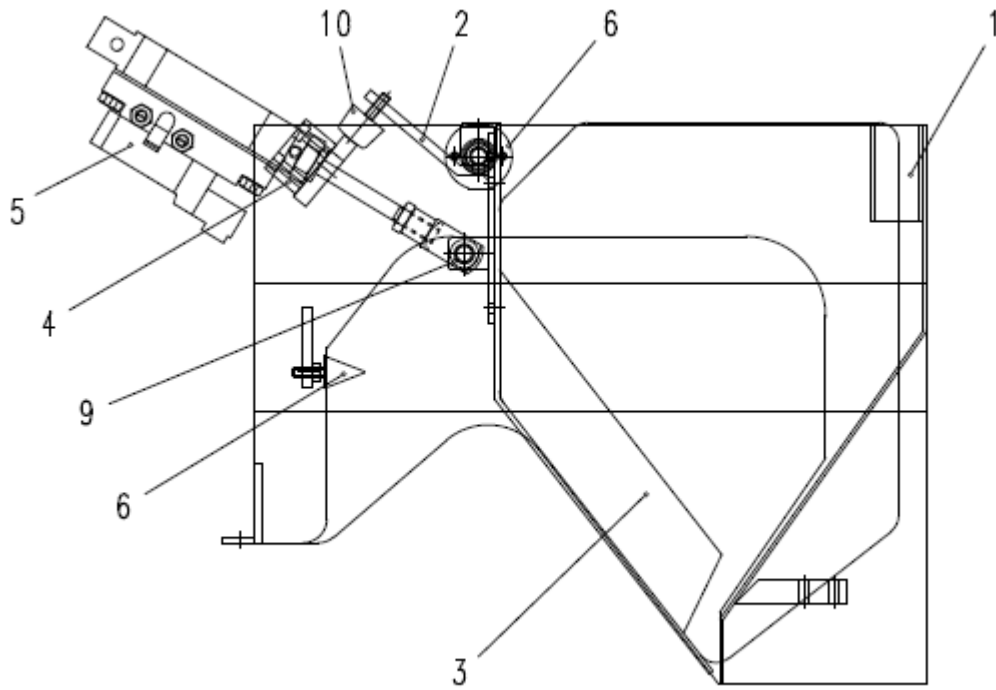
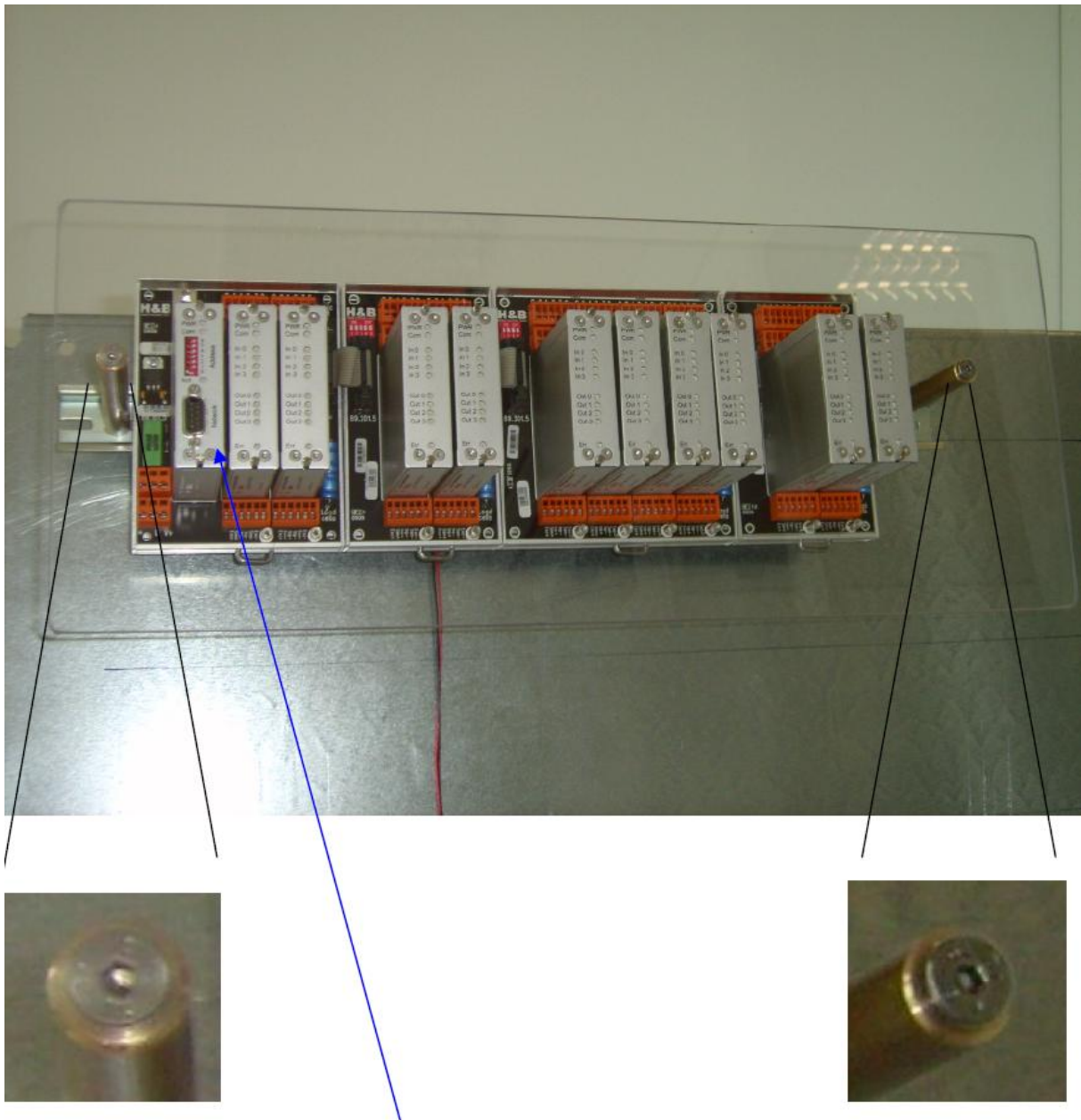

Figure 2: example of hopper with 1 door.



Cut out in plate for CAN connector

Figure 3: Sealing of LDM 88.1s and connectors by sealing the screws holding the transparent cover plate.