



We help ideas meet the real world

EC Type Examination Certificate

No. DK 0199.408 Revision 1

B6-KV

Vehicle Mounted Automatic Catchweighing Instrument

Issued by DELTA Danish Electronics, Light & Acoustics
EU - Notified Body No. 0199

In accordance with the requirements for the automatic weighing instrument of Directive 2004/22/EC of the European Parliament and Council on Measuring Instruments (MID).

Issued to Scaleit s.r.l.
Str.Laboratorului 7C
100 070 Ploiesti, Prahova
ROMANIA

In respect of Vehicle mounted automatic catchweighing instrument designated B6-KV with variants of modules of load receptors, load cells and peripheral equipment.
Accuracy class Y(a) or Y(b)
Maximum capacity: $10 \text{ kg} \leq \text{Max} \leq 3500 \text{ kg}$
Verification scale interval: $e_i \geq 0.2 \text{ kg}$
Maximum number of verification scale intervals: $n_i \leq 4000$ (however, dependent on environment and the composition of the modules).
Variants of modules and conditions for the composition of the modules are set out in the annex.

The conformity with the essential requirements in Annex 1 and the specific requirements in Annex MI-006, chapter I & II of the Directive 2004/22/EC is met by the application of OIML R51-1:2006, WELMEC Guide 7.2:2011 and WELMEC Guide 8.16-1:2006.

Note: This certificate is a revised edition which replaces previous revisions.

The principal characteristics and approval conditions are set out in the descriptive annex to this certificate.

The annex comprises 20 pages.

Issued on 2014-06-30
Valid until 2023-09-09

Signatory: J. Hovgård

DELTA
Venlighedsvej 4
2970 Hørsholm
Denmark

Tel. (+45) 72 19 40 00
Fax (+45) 72 19 40 01
www.delta.dk
VAT No. DK 12275110

Descriptive annex

| Contents | Page |
|--|-------------|
| 1. Name and type of instrument and modules | 2 |
| 2. Description of the construction and function | 2 |
| 2.1 Construction | 2 |
| 2.2 Function | 3 |
| 3. Technical data | 5 |
| 3.1 B6-KV | 5 |
| 3.2 B6000 analog data processing unit with inclinometer or accelerometer | 5 |
| 3.3 Load receptors, load cells, and load receptor supports | 6 |
| 3.4 Composition of modules | 7 |
| 3.5 Documents | 7 |
| 4. Interfaces and peripheral equipment | 7 |
| 4.1 Interfaces | 7 |
| 4.2 Peripheral equipment | 7 |
| 5. Approval conditions | 8 |
| 5.1 Connection of cables | 8 |
| 5.2 Application program | 8 |
| 5.3 Compatibility of modules | 8 |
| 6. Special conditions for verification | 8 |
| 6.1 Composition of modules | 8 |
| 6.2 Application software | 8 |
| 7. Securing and location of seals and verification marks | 9 |
| 7.1 Securing and sealing | 9 |
| 7.2 Verification marks | 10 |
| 8. Location of CE mark of conformity and inscriptions | 10 |
| 8.1 CE mark | 10 |
| 8.2 Inscriptions near the display | 10 |
| 8.3 Inscription plate | 10 |
| 8.4 Manufacturer's trademark | 11 |
| 9. Pictures | 12 |
| 10. Composition of modules - example | 20 |

1. Name and type of instrument and modules

The instrument is a battery operated vehicle-mounted automatic catch weighing instrument designated B6-KV. The instrument is designed for weighing waste on a refuse collection vehicle.

The weighing instrument consists of a load receptor with strain-gauge load cells and either an acceleration sensor or inclination sensor mounted on the bin lifter of a refuse collection vehicle. On the lifter there is also a sensor for determining the weighing window or weighing position. The electronic weight control unit B6000 and its display unit are mounted in the cabin of the vehicle.

2. Description of the construction and function

2.1 Construction

2.1.1 B6000 analog data processing unit

The module is specified in Section 3.2.

The B6000 unit is housed in a metal enclosure. It is designed primarily for automotive use, but may also be used in an industrial or office environment. See Figure 3.

B6000 consists of a mainboard with microprocessor, memory and interfaces, and one or two scale interface boards each having two identical channels. For each channel there is one strain gauges load cell interface and one interface for analog sensors as for example inclinometers, accelerometers or position sensors.

B6000 can therefore be equipped with up to two scales (see Figure 4) or with up to four scales (see Figure 5).

2.1.2 Display and key pad unit

B6000 has two possibilities for a display and key input.

- A VGA touch screen
- RemoteGFX

A VGA touch screen is connected to the VGA interface of B6000 over which it receives the displayed screen. The touch screen feature communicates key presses to B6000 using a USB connection.

RemoteGFX is a PC Windows application using an Ethernet connection for streaming B6000's display screen into a dedicated area of RemoteGFX's window. Mouse clicks within this dedicated area are sent to B6000 as key inputs. When the RemoteGFX application is started, it checks the integrity of the application and will only start if it is ok. B6000 has a fixed IP address and the PC running RemoteGFX shall have an IP address from the same subnet.

2.1.3 IS2A inclinometer

Each of the scale of B6000 may be equipped with a 2-axis inclinometer of type IS2A for tilt compensation.

The specifications for B6000 when used with IS2A are specified in Section 3.2.

2.1.4 AS1A accelerometer

Each of the scale of B6000 may be equipped with a 1-axis accelerometer of type AS1A for Gravitational compensation.

The specifications for B6000 when used with AS1A are specified in Section 3.2.

2.1.5 Load receptors, load cells, and load receptor supports

Set out in Section 3.3.

2.1.6 Interfaces and peripheral equipment

Set out in Section 4.

2.1.7 Alternative applications

The instrument may also be used for other applications than weighing refuse.

2.2 Function

The primary functions provided are detailed below.

2.2.1 Functions and devices

The automatic weighing instrument has the following permitted functions and devices that are subject to the Measuring Instrument Directive:

- Power up test
- Initial zero setting device (20 % of Max)
- Semiautomatic zero setting device (4 % of Max) – static mode only
- Zero tracking device (4 % of Max) – static mode only
- No motion detection and indication
- Tare weighing mode
- Tilt compensation (up to 10° in any direction)
- Alibi memory
- Real time clock
- Detection of significant fault

2.2.2 Automatic weighing function

The weighing instrument automatically determines the weight of a loaded bin during lifting, and then the weight of the empty bin on the way down to make it possible to calculate the net weight of the emptied refuse.

The instrument can be configured to either make two separate weighing based on which the net weight can be calculated or to measure the net weight directly using the weighing on the way down as tare balancing.

The weight data is usually transferred from the automatic weighing instrument to an onboard computer where it is stored locally before being sent to central office for storage and invoice purposes.

The weighing is usually set to start automatically based on the lifter position. There are two different weighing algorithms available for different applications; static and dynamic. In static mode the lift is stopped and the weight is recorded only when it is stable. In dynamic mode sample weights are taken continuously within a specified window of the lifter position. The instrument is setup to weigh in either Static or Dynamic mode. Whether the instrument is static or dynamic is marked on the data plate of the instrument.

2.2.2.1 Static operation

The following sequence of events applies in Static mode:

- Bin is placed on lifter and the lift begins.
- The lifter position is monitored until the weighing position is reached.
- The lifter is stopped and the weight is recorded when stability is reached.
- Then the lifter starts moving upwards again.
- The weight is calculated and the bin is emptied.
- The lifter is stopped again during the down cycle and the weight of the empty bin is measured.
- Cycle complete.

2.2.2.2 Dynamic operation

The following sequence of events applies in Dynamic mode:

- Bin is placed on lifter and the lift begins.
- The lifter position is monitored until the lower position is reached.
- The weighing starts and continues until the upper position is reached.
- The weight is calculated and the bin is emptied.
- The lifter position is again monitored until the upper position is reached.
- The weighing starts and continues until the lower position is reached.
- The weight is calculated.
- Cycle complete.

2.2.3 Allowed bin weight

The weight measured during downwards of the empty bin is checked against an “Allowed bin weight” range. Weights that are found to be outside this range will be marked with an error code.

2.2.4 Large bins

The system is designed for weighing of individual containers. To weigh large bins, the weight from two (2) instruments may be used to calculate the total weight.

2.2.5 Software version

The software version has the format x.yy.zz, where x is the legal version number, yy is used for minor non-legal revision, and zz is used for error corrections.

The software version can be displayed upon request.

The approved software version is 2.yy.zz.

The software version of RemoteGFX application software is 1.0.0.

The indicator may have optional user specified software application programs. When the indicator is unsealed, application software can be downloaded. Application software is not covered by this approval.

3. Technical data

The automatic catch weighing instrument has the following characteristics:

3.1 B6-KV

| | |
|---|---|
| Type: | B6-KV |
| Independent scales: | 1 to 4 |
| Accuracy class: | Y(a) or Y(b) |
| Weighing range: | Single-interval / multi-interval (up to 9 intervals) |
| Maximum capacity (Max_i): | 10 kg to 3500 kg |
| Minimum capacity (Min_i): | $20 \times e_1$ (class Y(a)), $10 \times e_1$ (class Y(b)), $5 \times e_1$ for instruments weighing waste. |
| Number of Verification Scale Intervals (n_i): | ≤ 4000 (class Y(a)), ≤ 1000 (class Y(b)) per interval |
| Verification scale interval (e_i): | Max_i / n_i and ≥ 0.2 kg |
| Tilting: | $\leq 10^\circ$ (17.6 %) in any direction |
| Maximum tare effect: | -Max within display limits |
| External mains power supply: | 12 VDC or 24 VDC |
| Electromagnetic class: | E3 |
| Humidity: | Non-condensing |
| Temperature range: | -10° to 40° C |
| Peripheral interface: | Set out in Section 4 |

3.2 B6000 analog data processing unit with inclinometer or accelerometer

| | |
|---|---|
| Type: | B6000 |
| Independent channels for scales: | 1 to 4 |
| Accuracy class: | Y(a) or Y(b) |
| Weighing range: | Single-interval / multi-interval (up to 9 intervals) |
| Maximum capacity (Max_i): | $n_i \times e_i$ |
| Minimum capacity (Min_i): | $20 \times e_1$ (class Y(a)), $10 \times e_1$ (class Y(b)), $5 \times e_1$ for instruments weighing waste. |
| Number of Verification Scale Intervals (n_i): | ≤ 4000 (class Y(a)), ≤ 1000 (class Y(b)) per interval |
| Verification scale interval (e_i): | Max_i / n_i |
| Internal resolution: | $> 1,000,000$ counts |
| Maximum tare effect: | -Max within display limits |
| Fractional factor: | $\pi = 0.5$ |
| Minimum input-voltage per VSI: | $0.5 \mu\text{V}$ |
| Excitation voltage: | 10 Vdc |
| Minimum signal voltage for dead load: | 0 mV |
| Analogue range: | 0 to 28 mV |
| Minimum input-impedance: | 43 ohm |
| Maximum input-impedance: | 1100 ohm |
| Circuit for remote sense: | present, using 6-wire cable to junction box |
| External mains power supply: | 12 VDC or 24 VDC |
| Power supply from road vehicle: | Allowed |
| Temperature range: | -10° to 40° C |
| Peripheral interface: | Set out in Section 4 |

3.2.1 Connecting cable between the B6000 and load cell / junction box for load cell(s)

3.2.1.1 4-wire system

Line: 4 wires, shielded
Maximum length: the certified length of the load cell cable, which shall be connected directly to the B6000.

3.2.1.2 6-wire system

Line: 6 wires, shielded

Option 1:

Maximum length: 3091 m/mm² (for n = 4000)

Option 2:

In case the (n) for the weighing instrument is less than (n) mentioned above, the following apply:

Coefficient of temperature of the span error of the indicator: $E_s = 0.0025$ [% / 25K]

Coefficient of resistance for the wires in the J-box cable: $S_x = 0.0018$ [% / ohm]

$L/A_{max} = 295.86 / S_x * (emp / n - E_s)$ [m / mm²] in which $emp = \pi * mpe * 100 / e$

From this, the maximum cable length for the weighing instrument may be calculated with regard to (n) for the actual configuration of the instrument.

Reference: See Section 10.

The calculation program is obtainable by downloading at www.delta.dk/weighing.

3.3 Load receptors, load cells, and load receptor supports

3.3.1 Load cells

| Manufacturer | Model | Capacity | Test Cert No. |
|----------------|-------|----------|---------------|
| Flintec | PCBB | 1000 kg | D09-01.02 |
| Flintec | PC2H | 2000 kg | D09-06.17 |
| Vishay | 1320 | 2000 kg | TC2274 |
| Vishay | 1320 | 1000 kg | TC2274 |
| Vishay | 620 | 5000 kg | GB-1046 |
| Load Indicator | FLG | 5000 kg | 0402-MTm037 |

3.3.2 Load receptor configurations

| Load cell | No of l.c. | Max | e | n |
|----------------|------------|-----------|----------|-------|
| PCBB-C3-1000kg | 1 | ≤ 300 kg | ≥ 0.2 kg | ≤ 600 |
| PCBB-C3-1000kg | 2 | ≤ 600 kg | ≥ 0.5 kg | ≤ 600 |
| PC2H-C3-2000kg | 1 | ≤ 750 kg | ≥ 0.5 kg | ≤ 600 |
| PC2H-C3-2000kg | 2 | ≤ 1500 kg | ≥ 1 kg | ≤ 600 |
| 1320-C3-1000kg | 1 | ≤ 300 kg | ≥ 0.2 kg | ≤ 600 |
| 1320-C3-2000kg | 1 | ≤ 600 kg | ≥ 0.5 kg | ≤ 600 |
| 620-C3-5000kg | 2 | ≤ 3500 kg | ≥ 2 kg | ≤ 600 |
| FLG-5000kg | 2 | ≤ 3500 kg | ≥ 5 kg | ≤ 600 |

3.4 Composition of modules

In case of composition of modules, EN 45501 paragraph 3.5 and 4.12 shall be satisfied.

3.5 Documents

The documents filed at DELTA (reference No. T203055) are valid for the weighing instruments described here.

4. Interfaces and peripheral equipment

4.1 Interfaces

The interface connectors are placed on the rear side of the B6000 unit.

The interfaces 4.1.3 to 4.1.6 are characterised "Protective interfaces" according to paragraph 8.4 in the Directive and do not have to be secured.

4.1.1 Load cell interface

The B6000 unit can be equipped with 2 or 4 individual load receptor interfaces – one for each scale.

4.1.2 Inclinator / accelerometer interface

2 or 4 inclinometer interfaces - each having a DSUB-15 connector - are placed on the rear side of the B6000 unit for connection of the inclinometers – if used.

4.1.3 VGA interface

Used for connection to a VGA screen serving as primary display.

4.1.4 USB interfaces

One of the three USB interfaces is used for connection to a touch screen display for key press input.

4.1.5 Ethernet

Used for connection to a PC with the RemoteGFX software running as primary display.

4.1.6 Serial I/O interface

The “COM EXT” and “DATA” interfaces can be configured as either RS232 or RS485.

4.1.7 Logic level inputs

Each MIO connector provides 2 logic level inputs. These inputs may be used for external function keys, for example Tare, Zero or Print.

4.2 Peripheral equipment

Connection between the B6000 and peripheral equipment is allowed by screened cable.

The instrument may be connected to any simple peripheral device with a CE mark of conformity.

5. Approval conditions

5.1 Connection of cables

All communication cables shall be shielded and the shield shall be properly EMC wise connected to the housing / connector in both ends.

5.2 Application program

The B6000 may have optional user specified software application programs. Application software can only be downloaded when the B6000 is unsealed.

Application software is not covered by this approval, but its integrity can be checked at verification (see Section 6.2.1).

5.3 Compatibility of modules

In case of composition of modules, WELMEC 2 (Issue 5) 2009, paragraph 11 shall be satisfied.

6. Special conditions for verification

Each scale interface board has its own hardware calibration switch, so it is possible to calibrate scale 1 and 2, respectively 3 and 4 independent of the two other scales.

The initial verification shall be performed according to OIML R51.

6.1 Composition of modules

The composition of modules shall agree with Section 5.3.

An example of a declaration of conformity document is shown in Section 10.

6.2 Application software

If an application software is running, the label at the top of the screen displays “Application mode” and which software that is currently running. Top left there is a button labeled “Main”, press it to return to the main window. Toggle back to the application software by pressing the “triple arrow” key on the right.

6.2.1 Verify the integrity of the weight

If an application software is running, the following checks may be made to verify the integrity of the displayed weight and transmitted weight data.

Displayed weight:

1. Activate the application software.
2. Place a weight on the load receiver and record the displayed value.
3. With the load still on the platform, toggle back to the main window.
4. Note the displayed weight. It must be exactly as shown by the application program and recorded in step 2.

Transmitted weight data:

1. If the application program transmits weight on an interface, a check may be made to verify its integrity. With the application program running, inspect the weight data transmitted (if any) from the interface.
2. Toggle back to the main window. Using a display terminal or similar device, connect it to the standard printer port and view the weight data transmitted from this protective interface.

The gross and/or net weights transmitted from the standard program must be the same as the weight from the application program.

7. Securing and location of seals and verification marks

7.1 Securing and sealing

Seals shall bear the mark of the manufacturer or alternative the verification mark of a notified body according to Directive 2004/22/EC.

7.1.1 B6000 analog data processing unit

Access to the configuration and calibration facility is achieved by placing the internal calibration switch (located on the scale input board) in the ON position. Sealing of the switch is accomplished by covering it with a tamper evident label. The top and bottom panel of the indicator housing shall be secured with lead seals or tamper evident labels.

7.1.2 Junction box for load cells

The load cell junction box shall be secured by use of lead seals or tamper evident labels, unless the serial numbers of the load cells are marked on the inscription plate.

7.1.3 Cable from junction box

The connector on the cable between indicator and junction box shall be secured by use of lead seals or tamper evident labels.

7.1.4 Inclination sensor

The inclination sensor housing and the cable between indicator and housing shall be secured by use of lead seals or tamper evident labels.

7.1.5 Cable from inclination sensor

The connector on the cable between indicator and inclination sensor, shall be secured by use of lead seals or tamper evident labels.

7.1.6 Acceleration sensor

The acceleration sensor housing and the cable between indicator and housing shall be secured by use of lead seals or tamper evident labels.

7.1.7 Cable from acceleration sensor

The connector on the cable between indicator and acceleration sensor, shall be secured by use of lead seals or tamper evident labels.

7.1.8 Data plate

The data plate is located on a visible part of the instrument. It is secured, either by sealing or by being of a form such that it is destroyed when removed. If the data plate is sealable, it shall be possible to apply a control mark to it.

7.1.9 Peripheral interfaces

All peripheral interfaces are “protective”; they neither allow manipulation with weighing data or legal setup, nor change of the performance of the weighing instrument in any way that would alter the legality of the weighing.

7.2 Verification marks

7.2.1 Indicator

A metrological M shall be placed next to the CE mark on the inscription plate.

The sticker with verification marks may be placed on or next to the inscription plate or on the front of the indicator.

7.2.2 Printers used for legal transactions

Printers covered by this type approval and other printers according to Section 4.2, which have been subject to the conformity assessment procedure, shall not bear a separate marking in order to be used for legal transactions.

8. Location of CE mark of conformity and inscriptions

8.1 CE mark

The CE mark with the two last digits of the year of production is located on the inscription plate.

8.2 Inscriptions near the display

The display unit shall bear the following inscriptions,

- Serial number of connected B6000 unit

And for each configured scale,

- Max (Max_i for multi-interval)
- Min
- $e = (e_i$ for multi-interval)

These inscriptions shall be visible when the instrument is in its regular operating position.

8.3 Inscription plate

The inscription plate of the instrument shall in addition to CE mark and metrological M contain at least the following,

- Manufacturer's name and/or trademark
- Type : B6-KV
- Serial number of the instrument
- EC type examination certificate number
- Supply voltage

And for each configured scale,

- Scale input number in the form SIB 1-4
- Static or Dynamic mode
- Max (Max_i for multi-interval)
- Min
- $e = (e_i$ for multi-interval)
- accuracy class

8.4 Manufacturer's trademark

The manufacturer places one of the following trademarks on the instrument.



Old Trademark.



New Trademark

9. Pictures

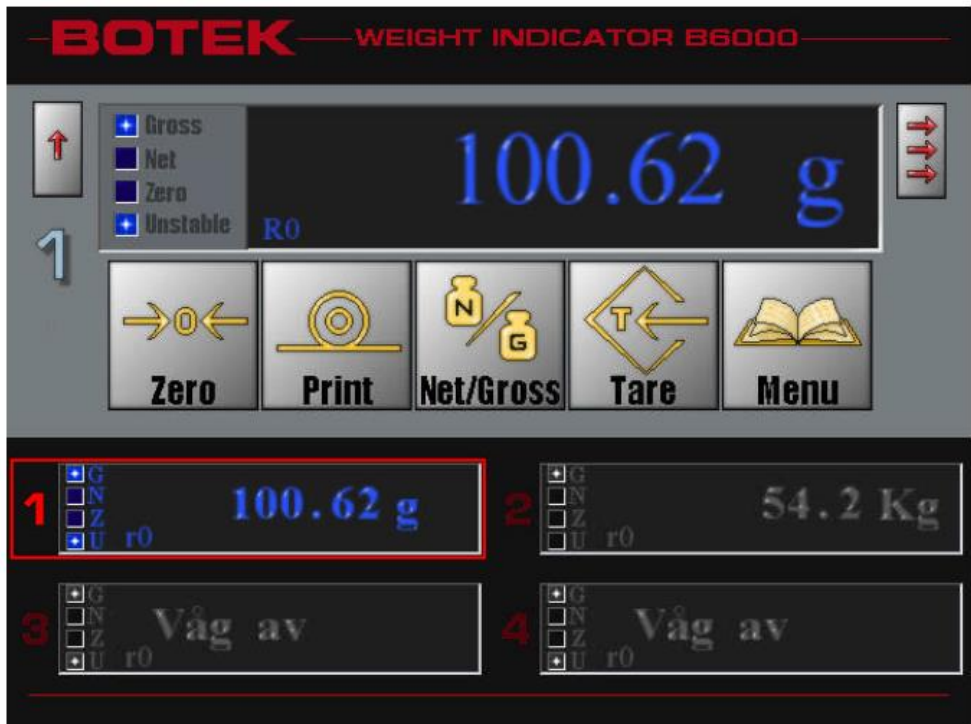

Figure 1 VGA touch screen display

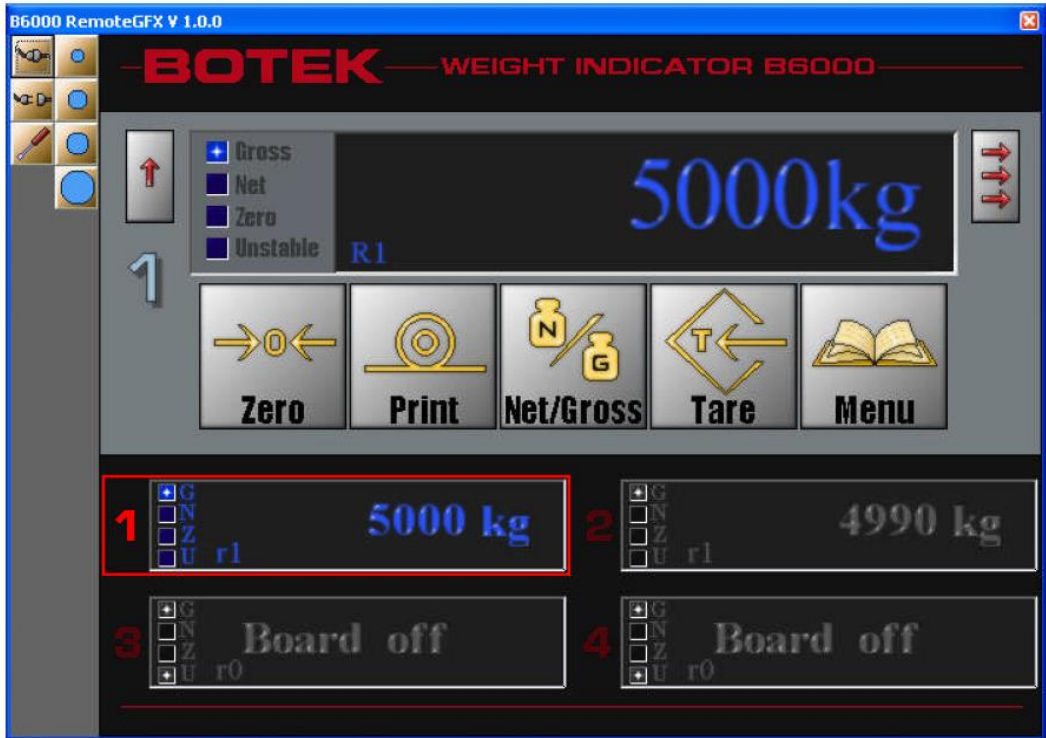

Figure 2 Display using RemoteGFX on a PC





Figure 3 B6000 front panel



Figure 4 B6000 rear panel – with 2 scale channels



Figure 5 B6000 rear panel – with 4 scale channels



Figure 6 IS2A inclinometer

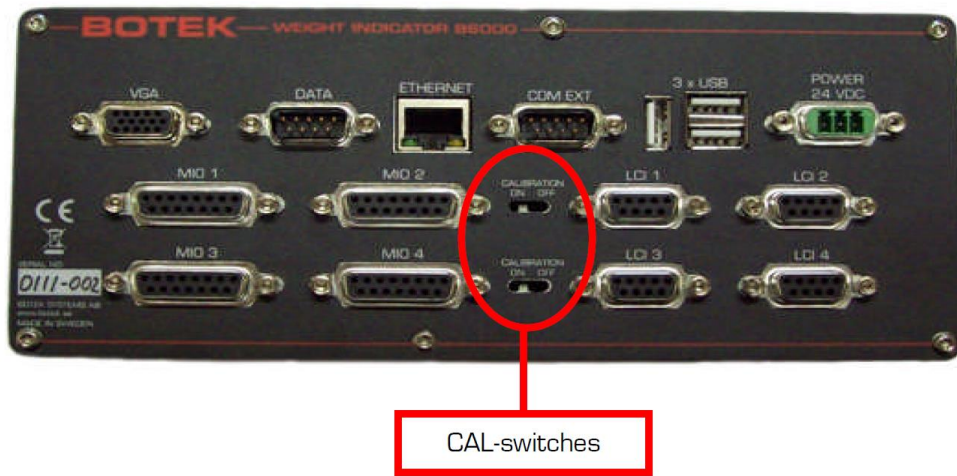

Figure 7 Calibration switches to be sealed.

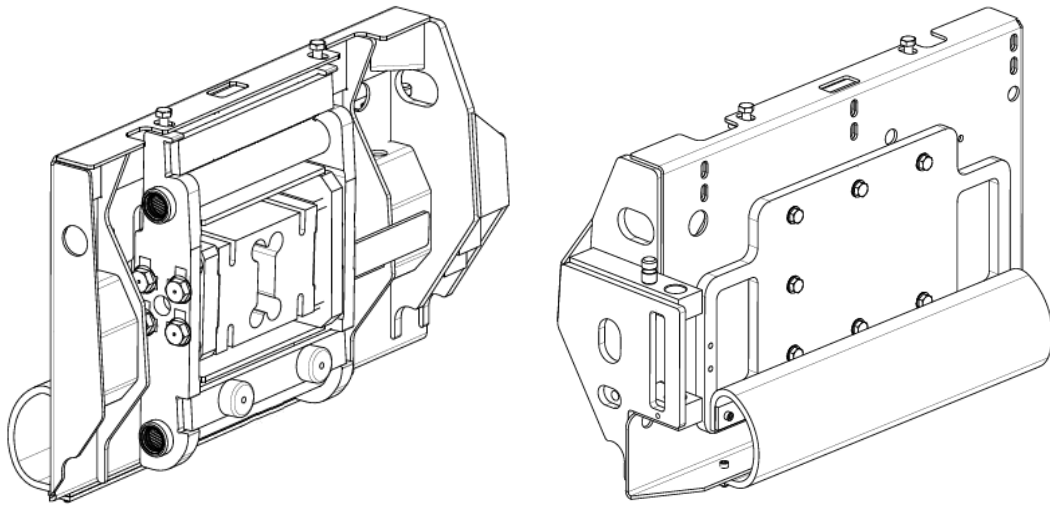

Figure 8 Example of installation of single point load cell mounted on a rear loader or side loader

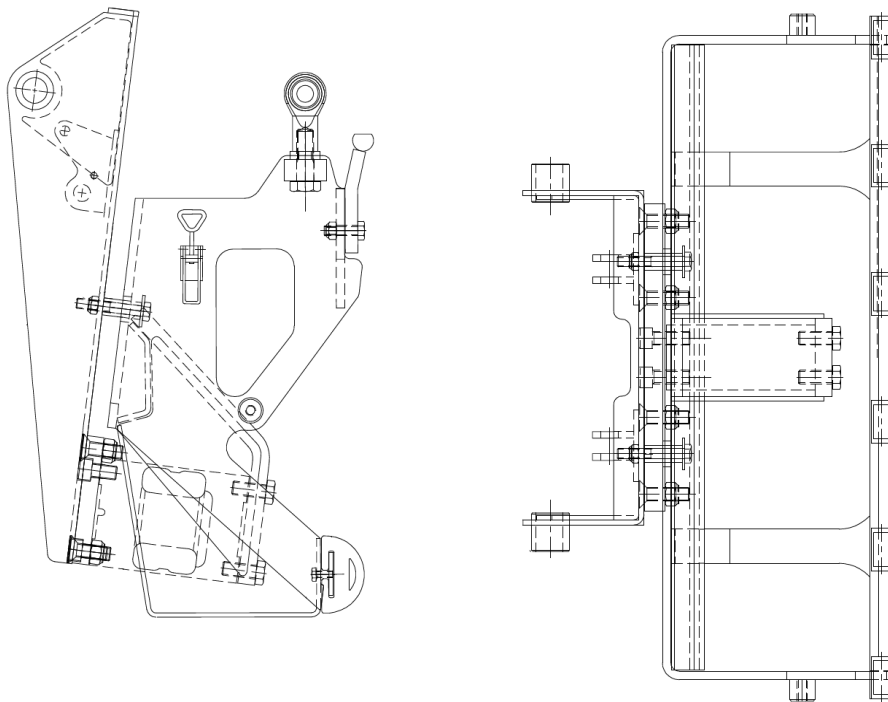

Figure 9 Example of installation of single point load cell mounted on a side loader

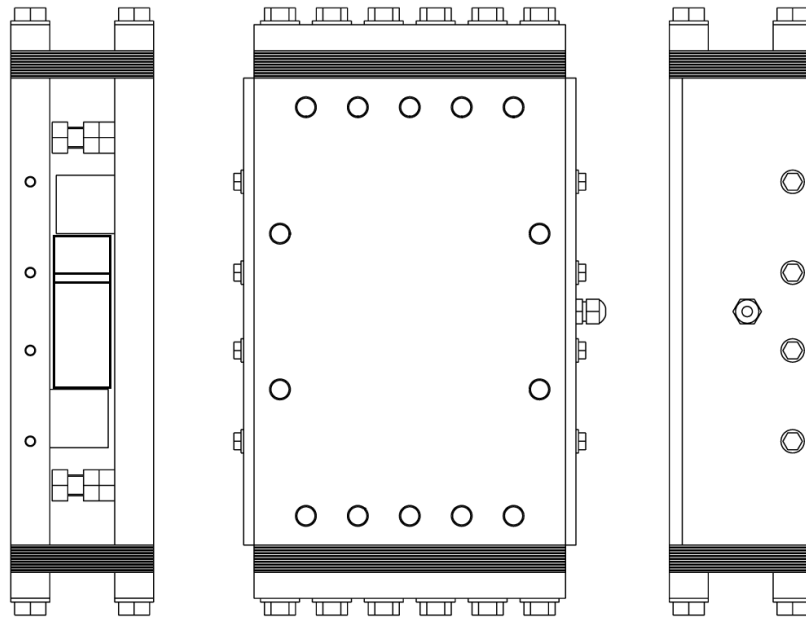

Figure 10 Example of installation of mechanical system with impact for load cell model 620

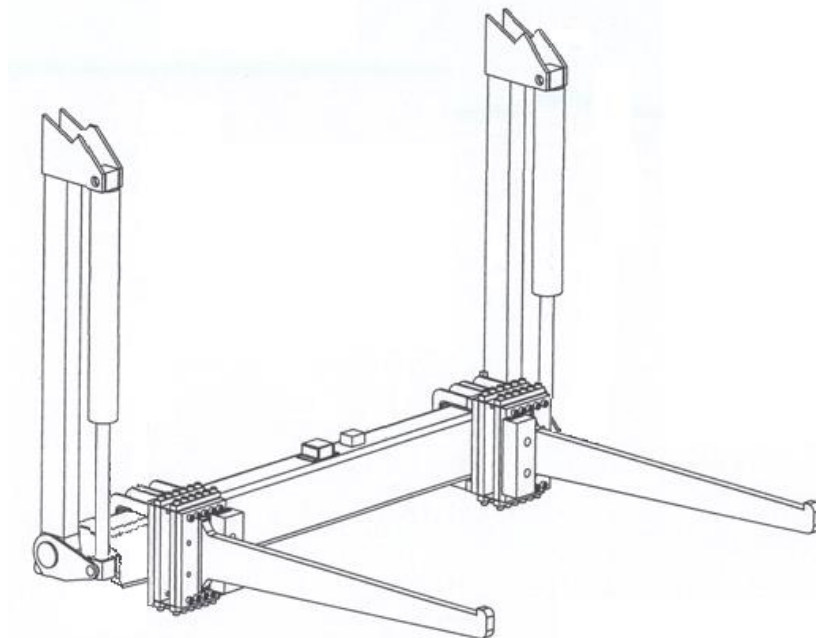

Figure 11 Example of installation of load cell model 620 mounted on a front loader

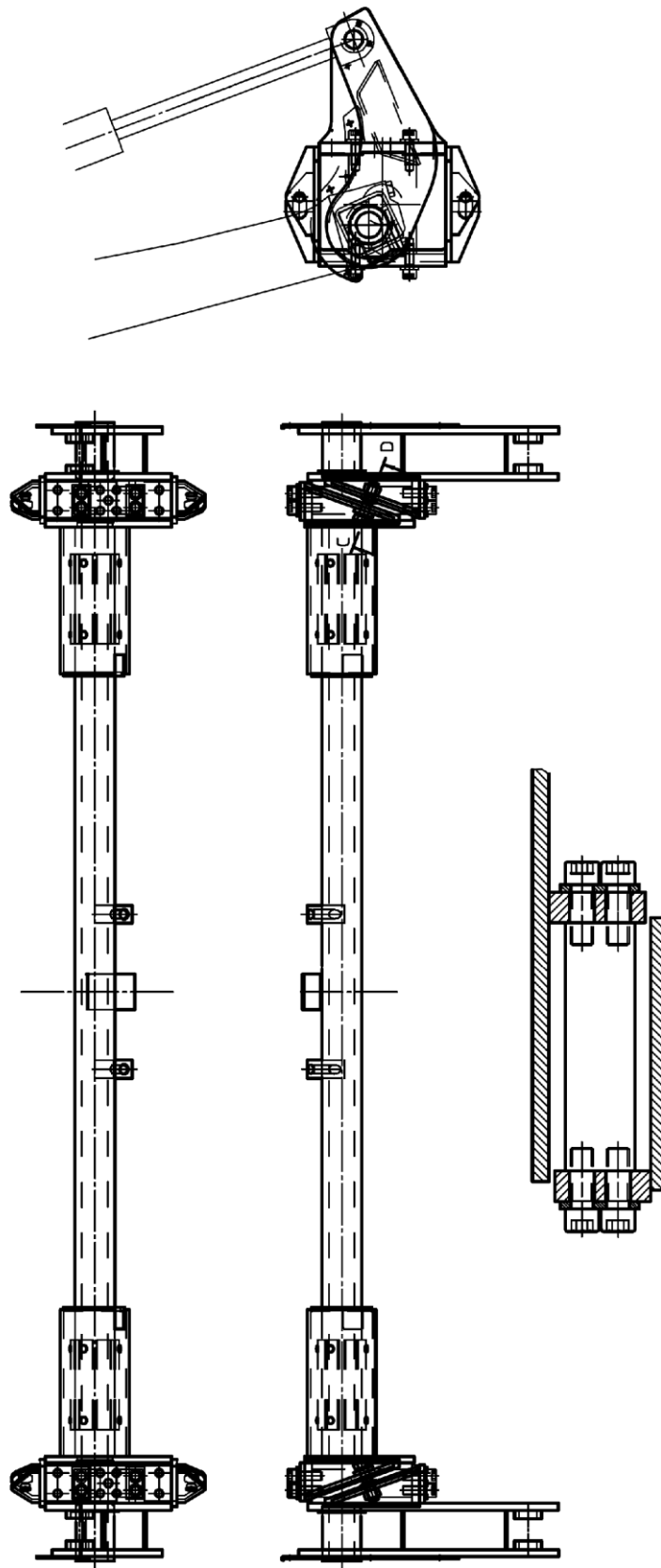

Figure 12 Example of installation of load cell model FLG mounted on a front loader

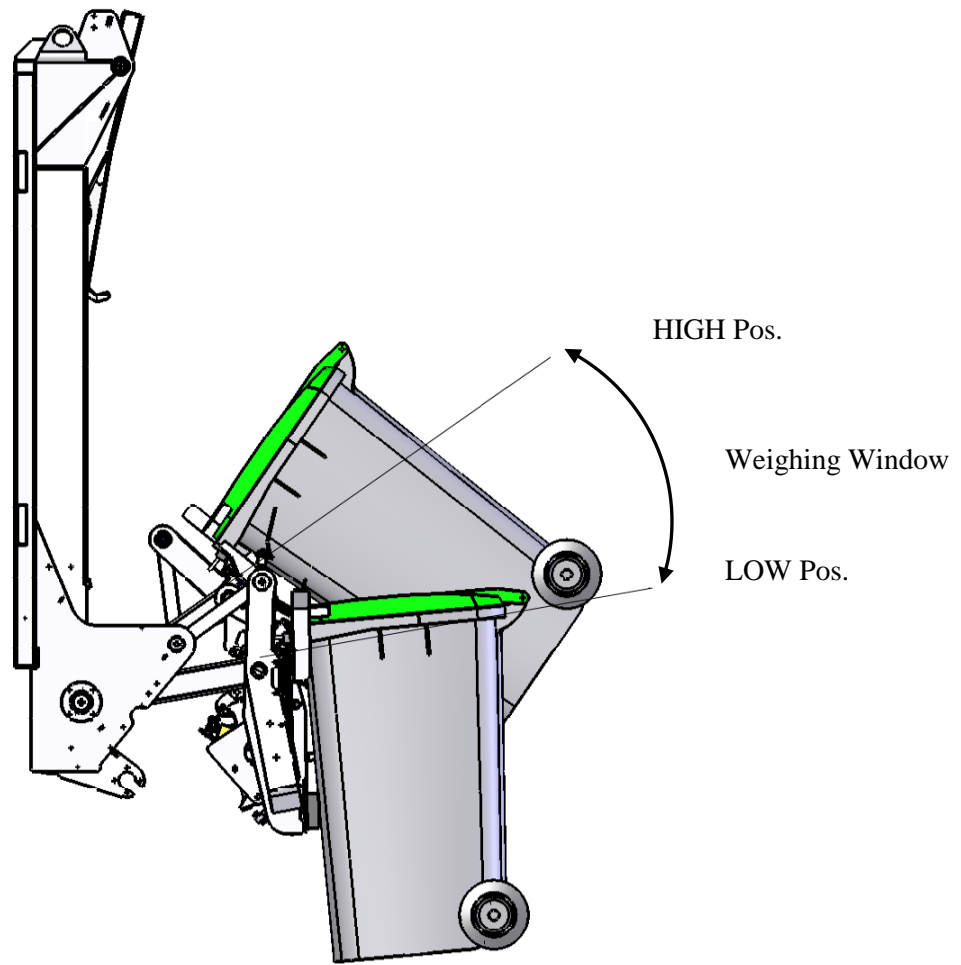

Figure 13 Weighing window for rear loader

10. Composition of modules - example

COMPATIBILITY OF MODULES

Ref.: WELMEC 2

Non-Automatic Weighing Instrument, single-interval

Certificate of EU Type-Approval N°:

TAC: DK0199.408

INDICATOR

A/D (Module 1)

Type: B6000 w. IS2A inclinometer

Accuracy class according to EN 45501 and OIML R76:

Class_{ind} (I, II, III or IIII) III

Maximum number of verification scale intervals (n_{max}):

n_{ind} 4000

Fraction of maximum permissible error (mpe):

p₁ 0,5

Load cell excitation voltage:

U_{exc} [Vdc] 10

Minimum input-voltage per verification scale interval:

Δu_{min} [μV] 0,5

Minimum load cell impedance:

R_{Lmin} [Ω] 43

Coefficient of temperature of the span error:

Es [% / 25°C] 0,0025

Coefficient of resistance for the wires in the J-box cable:

Sx [% / Ω] 0,00156

Specific J-box cable-Length to the junction box for load cells:

(L/A)_{max} [m / mm²] 3082

Load cell interface:

6-wire (remote sense)

Additive tare, if available:

T⁺ [% of Max] 0

Initial zero setting range:

IZSR [% of Max] -10 / 10

Temperature range:

T_{min} / T_{max} [°C] -10 / 40

Test report (TR), Test Certificate (TC) or OIML Certificate of Conformity:

LOAD RECEPTOR

(Module 2)

Type: Rear loader

Construction:

Optional

Fraction of mpe:

p₂ 0,5

Number of load cells:

N 1

Reduction ratio of the load transmitting device:

R=F_M / F_L 1

Dead load of load receptor:

DL [% of Max] 30

Non uniform distribution of the load:

(NUD = 0 is acceptable) NUD [% of Max] 50

Correction factor:

Q = 1 + (DL + T⁺ + IZSR⁺ + NUD) / 100 1,9

LOAD CELL

ANALOG (Module 3)

Type: PCB-B-C3-1000kg

Accuracy class according to OIML R60:

Class_{LC} (A, B, C or D) C

Maximum number of load cell intervals:

n_{LC} 3000

Fraction of mpe:

p₃ 0,7

Rated output (sensitivity):

C [mV / V] 2

Input resistance of single load cell:

R_{LC} [Ω] 350

Minimum load cell verification interval:

(V_{min%} = 100 / Y) V_{min%} [% of E_{max}] 0,008

Rated capacity:

E_{max} [kg] 1000

Minimum dead load, relative:

(E_{min} / E_{max}) * 100 [%] 0

Temperature range:

T_{min} / T_{max} [°C] -10 / 40

Test report (TR) or Test Certificate (TC/OIML) as appropriate:

D09-01.02

COMPLETE WEIGHING INSTRUMENT

Single-interval

Manufacturer:

Scaleit s.r.l.

Type: B6-KV

Accuracy class according to EN 45501 and OIML R76:

Class_{WI} (I, II, III or IIII) III

Fractions: p₁ = p₁² + p₂² + p₃²:

p_i 1,0

Maximum capacity:

Max [kg] 300

Number of verification scale intervals:

n 600

Verification scale interval:

e [kg] 0,5

Utilisation ratio of the load cell:

α = (Max / E_{max}) * (R / N) 0,30

Input voltage (from the load cells):

Δu = C * U_{exc} * α * 1000 / n [μV/e] 10,00

Cross-section of each wire in the J-box cable:

A [mm²] 0,22

J-box cable-Length:

L [m] 20

Temperature range to be marked on the instrument:

Not required T_{min} / T_{max} [°C]

Peripheral Equipment subject to legal control:

| Acceptance criteria for compatibility | | Passed, provided no result below is < 0 | |
|--|---|---|--------|
| Class _{WI} | <= Class _{ind} & Class _{LC} (WELMEC 2: 1) | Class _{WI} | PASSED |
| p _i | <= 1 (R76: 3.5.4.1) | 1 - p _i | 0,0 |
| n | <= n _{max} for the class (R76: 3.2) | n _{max} for the class - n | 9400 |
| n | <= n _{ind} (WELMEC 2: 4) | n _{ind} - n | 3400 |
| n | <= n _{LC} (R76: 4.12.2) | n _{LC} - n | 2400 |
| E _{min} | <= DL * R / N (WELMEC 2: 6d) | (DL * R / N) - E _{min} | 90 |
| V _{min} * √N / R | <= e (R76: 4.12.3) | e - (V _{min} * √N / R) | 0,420 |
| or (if V _{min} is not given) | | Alternative solutions: | |
| (E _{max} / n _{LC}) * (√N / R) | <= e (WELMEC 2: 7) | e - ((E _{max} / n _{LC}) * (√N / R)) | |
| Δu _{min} | <= Δu (WELMEC 2: 8) | Δu - Δu _{min} | 9,50 |
| R _{Lmin} | <= R _{LC} / N (WELMEC 2: 9) | (R _{LC} / N) - R _{Lmin} | 307 |
| L / A | <= (L / A) _{max} ^{WI} (WELMEC 2: 10) | (L / A) _{max} ^{WI} - (L / A) | 23142 |
| T _{range} | <= T _{max} - T _{min} (R76: 3.9.2.2) | (T _{max} - T _{min}) - T _{range} | 20 |
| Q * Max * R / N | <= E _{max} (R76: 4.12.1) | E _{max} - (Q * Max * R / N) | 430,0 |

Signature and date:

Conclusion PASSED

This is an authentic document made from the program:
"Compatibility of NAVI-modules version 3.2".

