



We help ideas meet the real world

EC Type Examination Certificate

No. DK 0199.446

BX3

AUTOMATIC GRAVIMETRIC FILLING INSTRUMENT

Issued by DELTA Danish Electronics, Light & Acoustics
EU - Notified Body No. 0199

In accordance with the requirements for the automatic weighing instruments in Directive 2004/22/EC of the European Parliament and Council of March 31, 2004 on Measuring Instruments (MID).

Issued to Afm Elektrik Elektronik Otomasyon Ali Fuat Ozdemir
Fevzi Çakmak Mah.Aykent Sanayi Sitesi
10686 Sok. No:5
Karatay/Konya
TURKEY

In respect of An automatic gravimetric filling instrument designated **BX3** with variants of modules of load receptors, load cells and peripheral equipment.
Filling method: single fill
Reference class 0.2
Maximum capacity, $Max = n \times e$
Verification scale interval: $e \geq 0.5 \text{ g}$
Number of verification scale intervals: $n \leq 6000$ for single-interval
(however, dependent on environment and the composition of the modules)
Variants of modules and conditions for the composition of the modules are set out in the annex.

The conformity with the essential requirements in Annex 1 and the specific requirements in Annex MI-006, chapter I & III of the Directive 2004/22/EC is met by the application of OIML R61-1:2004, section 12 & 13 of OIML D11:2004, WELMEC Guide 7.2, and WELMEC Guide 8.16-2:2006.

The principal characteristics and approval conditions are set out in the descriptive annex to this certificate.

The annex comprises 17 pages.

Issued on 2014-03-14
Valid until 2024-03-14

Signatory: J. Hovgård

DELTA
Venlighedsvej 4
2970 Hørsholm
Denmark

Tel. (+45) 72 19 40 00
Fax (+45) 72 19 40 01
www.delta.dk
VAT No. DK 12275110

Descriptive annex

Contents		Page
1.	Name and type of instrument and modules	2
2.	Description of the construction and function	2
2.1	Construction	2
2.2	Functions	2
3.	Technical data	5
3.1	BX3 Automatic gravimetric filling instrument	5
3.2	Indicator	6
3.3	Load cells	7
3.4	Load receptors	7
3.5	Composition of modules	8
3.6	Documents	8
4.	Interfaces and peripheral equipment	8
4.1	Interfaces	8
4.2	Peripheral equipment	9
5.	Approval conditions	9
5.1	The legal metrology parameter (par. 200) must be adjusted as 1	9
5.2	Discontinuous totalisation is not approved.	9
5.3	Compatibility of modules	9
6.	Special conditions for verification	9
6.1	Composition of modules	9
7.	Securing and location of seals and verification marks	10
7.1	Securing and sealing	10
7.2	Verification marks	10
8.	Location of CE mark of conformity and inscriptions	11
8.1	Identification plate	11
9.	Pictures	12
10.	Composition of modules – an example	17

1. Name and type of instrument and modules

The automatic weighing instrument designated BX3 is an automatic gravimetric filling instrument consisting of an electronic weighing indicator connected to a separate load receptor and peripheral equipment such as printers or other devices, as appropriate.

The instrument is a self-indicating filling instrument with single-interval.

The modules appear from Sections 3.1, 3.2, and 3.3; the principle of the composition of the modules is set out in Sections 6.1 and 10.

2. Description of the construction and function

2.1 Construction

2.1.1 BX3 weighing indicator

The weighing indicator of the BX3 gravimetric filling instrument scale is FLINTAB's indicator type BX3.

The indicator consists of analogue to digital conversion, microprocessor control circuitry, power supply, keyboard, non-volatile memory for storage of calibration and weight data, option boards and a weight display contained within a single enclosure.

BX 3 indicator can be supplied either in desk type enclosure, stainless steel enclosure or panel type enclosure.

The module is specified in Section 3.2.

2.1.2 Load cells

Set out in Section 3.3.

2.1.3 Load receptor

Set out in Section 3.4.

2.1.4 Interfaces and peripheral equipment

Set out in Section 4.

2.2 Functions

The weighing indicator is microcontroller based electronics that requires the external connection of strain gauge based analogue load cells. The weight information appears in the digital display located on the front of the instrument and may be transmitted to peripheral equipment for recording, processing or display. There are available data output options such as binary data output, analogue output, Modbus, Ethernet etc.

The primary functions provided are detailed below. The key functions can be provided via opto-isolated inputs, serial interfaces, Modbus RTU, profibus, profinet and / or Ethernet.

The main functions are described below.

2.2.1 Power up

For legal metrological applications, on power up the indicator performs an automatic self-test and verification of all data storage components to ensure correctness of instruction, calibration and data memory.

During the self-test the following are displayed in sequence:

Variant name together with software version number and installed options for 10 seconds. All digits and later annunciators are illuminated for a short period of time and all digits counting up for a period of time.

In case of error, appropriate error messages are given.

After the test, the indicator will proceed with initial zero setting if this function is activated. The message [E E E] will remain in the display until pressing enter key for values out of initial zeroing range; but power on zero device does not perform its function in this case.

2.2.2 Test function

On power up the indicator will test all memory functions and cause all display elements to illuminate so that a visual verification of their operation can be made.

In case of error, appropriate error messages are given.

Serial data output port and digital I/O's can be tested via keypad in test mode.

2.2.3 Displayed range

The indicator displays from -2 % of Max (minus zeroing range) to Max + 9e1.

Under this range, the message “under” appears on the display.

Over this displaying range, the message “over” appears on the display.

If the input signal is out of the instrument input conversion range “ADC OUT” message appears.

2.2.4 Zero setting

Zero setting can only take place when the weight display is stable.

Pressing the ZERO key causes a new zero reference to be established and the ZERO annunciator to be illuminated at the centre of zero.

2.2.5 Automatic zero setting

Zero setting may take place during filling process, if programmed. The zero setting conditions are applied here.

2.2.6 Increased display resolution (in weighing mode)

The weight indicator is equipped with increased resolution, which operates after pressing the related key and functioning shorter than 5 seconds. It is not possible to get print out in increased resolution.

2.2.7 Tare device

The BX3 is equipped with a subtractive tare device, whereby the maximum tare capacity corresponds to the maximum indication of the scale. The condition for a taring is the equilibrium of the scale and

positive indication. The status tared is marked by the symbol “Net” on the display. Repeated pressing causes the tare to be cleared and new tare entered in its place.

The indicator BX3 tare device can be working in automation, like filling, depending on the application.

2.2.8 Automatic tare device

Tare setting may take place during filling process, if programmed. All tare device conditions are applied in this device.

2.2.9 Target (preset) value device

Value, expressed in units of mass, preset by the operator by means of the fill setting device, in order to define the nominal value of the fills.

2.2.10 Pre-act adjustment device

The setting of the fine feed cut-off value may be supplemented for minimising the filling deviation.

2.2.11 Zeroing period

The zeroing is performed automatically at the following filling after this time. The value entered here shall be less than or equal to the value calculated at the OIML R-61 section A.5.3.5 for approved usage and stated in Section 3.

2.2.12 Gross / Net indication device

If the instrument has Gross / Net key on it, the weight display can be switched from net indication to gross indication for five seconds by pressing the Gross / Net key.

2.2.13 Keyboard functions

According to the software of the instrument, the keys have various functions.

All key functions are described in the keyboard drawings in the manual of the BX3 indicator.

2.2.14 Real time clock

If it is available in the variant, the real time clock can be activated to get print out with day and time information.

2.2.15 Printing

The instrument can be connected to serial printers with the proper interface. It can be programmed to print date and time of weighing, consecutive number of printing that may be required together with weight / filling results.

Printing is not possible when the indicator is not stable or the display has a negative value.

2.2.16 Gravity acceleration

The gravity acceleration adjustment parameter can be used to compensate the weight difference between the place in which the instrument is calibrated and the place of usage. There is one parameter for this adjustment. The value entered in to this parameter before calibration is considered as a reference value. After calibration, the value in the parameter is seen as 0. For gravity adjustment, the new

value must be entered in to this parameter after calibration. After entering the new value, the calibration is automatically adjusted for the place of usage.

2.2.17 Adjusting device

Regarding the connection of the scale, the metrological relevant adjustment is filed in the memory of the evaluation electronics. The access to this adjusting mode or a change of these metrological adjustments is only possible after the short circuit of the calibration jumper.

2.2.18 Units

The family may be produced in any unit accepted in EU as kg, g, t, lb etc. For force measurement applications, the indicator will be accepted as a force measuring instrument and the unit may be force unit like Newton.

2.2.19 Software

The software versions of the BX3 weighing indicator are displayed at start-up.

The software version of the BX3 firmware is 02.xx, and the software version of the BX3 application is 01.yy, where xx and yy are sub-revision numbers for software changes not related to the legal functionality of the software.

3. Technical data

The automatic weighing instruments and its modules are set out as follows:

3.1 BX3 Automatic gravimetric filling instrument

Type:	BX3
Reference class:	0.2 or 0.5 or 1 or 2
Maximum capacity (Max):	= $n \times d$
Minimum capacity (Min):	= Minfill
Verification scale interval (d):	$\geq 0.5 \text{ g}$
Weighing range:	Single-interval
Number of Verification Scale Intervals (n):	≤ 6000
Maximum tare effect:	$\leq 100 \% \text{ of Max}$
Temperature range:	$-10^\circ \text{ to } 40^\circ \text{ C}$
Weighing mode:	static
Electromagnetic class:	E2
Humidity:	Non-condensing
Maximum time between automatic zero-setting:	90 minutes

Rated minimum fill (Minfill):

d	Reference accuracy class							
	X(0.2)		X(0.5)		X(1)		X(2)	
	d	[kg]	d	[kg]	d	[kg]	d	[kg]
0.5	56	0.028	22	0.011	11	0.0055	6	0.003
1	111	0.111	22	0.022	11	0.011	6	0.006
2	167	0.334	22	0.044	11	0.022	6	0.012
5	333	1.665	67	0.335	22	0.11	6	0.03
10	333	3.33	133	1.33	33	0.33	11	0.11
20	333	6.66	133	2.66	67	1.34	17	0.34
50	500	25	133	6.65	67	3.35	33	1.65
100	500	50	200	20	67	6.7	33	3.3
200	500	100	200	40	100	20	33	6.6
500	500	250	200	100	100	50	50	25
1000	500	500	200	200	100	100	50	50
≥ 2000	500	500 × d	200	200 × d	100	100 × d	50	50 × d

3.2 Indicator

The indicator has the following characteristics:

Type:	BX3
Accuracy class:	III and IIII
Weighing range:	Single interval
Maximum number of Verification Scale intervals:	6000
Maximum subtractive tare effect:	-Max, within display limits
Fractional factor:	$p'i = 0.5$
Minimum input voltage per VSI:	0.83 μ V
Minimum input voltage:	0 mV
Maximum input voltage:	20 mV
Excitation voltage:	5 VDC
Analogue range:	0 to 40 mV
Circuit for remote sense:	Active
Minimum input impedance:	58 ohm
Maximum input impedance:	1,200 ohm
Internal resolution:	Up to 8,000,000 counts

Operating temperature range:	-10° C to +40° C, up to 85% humidity non-condensing
Mains power supply:	230 VAC, 50 Hz 60 Hz or 12 VDC
Peripheral interface:	Set out in Section 4

3.2.1 Connecting cable between the indicator and a junction box for load cell(s), if any

Cable between indicator and junction box: 6 wires (sense), shielded

Maximum cable length between indicator and junction box (J-box) for load cell(s), if any:

- Option 1: 715 m/mm²

In case the (n) for the weighing instrument is less than (n) mentioned above, the following applies:

- Option 2:

Coefficient of temperature of the span error of the indicator: $E_s = 0.0044$ [% / 25K]

Coefficient of resistance for the wires in the J-box cable: $S_x = 0.00335$ [% / ohm].

$L/A_{max} = 295.86 / S_x * (emp / n - E_s)$ [m / mm²] in which $emp = p_i * mpe * 100 / e$

From this, the maximum cable length for the weighing instrument may be calculated with regard to (n) for the actual configuration of the instrument.

Reference: See Section 10.

The calculation program is obtainable by downloading at www.delta.dk/weighing.

3.3 Load cells

3.3.1 General acceptance of load cells

Any load cell(s) may be used for instruments under this certificate of type approval provided the following conditions are met:

- 1) A test certificate (EN 45501) or a respective OIML Certificate of Conformity (R60) is issued for the load cell by a Notified Body responsible for type examination under the Directive 2009/23/EC.
- 2) The certificate contains the load cell types and the necessary load cell data required for the manufacturer's declaration of compatibility of modules (WELMEC 2, Issue 5, 2009), and any particular installation requirements). A load cell marked NH is allowed only if humidity testing to EN 45501 has been conducted on this load cell.
- 3) The compatibility of load cells and indicator is established by the manufacturer by means of the compatibility of modules form, contained in the above WELMEC 2 document, or the like, at the time of EC verification or declaration of EC conformity of type.
- 4) The load transmission must conform to one of the examples shown in the WELMEC 2.4 Guide for load cells.

3.4 Load receptors

Removable platforms shall be equipped with level indicators.

3.4.1 Platforms

Construction in brief:	All-steel, aluminium, plastic, steel-reinforced concrete construction or hybrid construction of these materials. Bench, surface, pit or wall mounted.
Reduction ratio:	1
Junction box:	Mounted in, on or near the platform.
Load cells:	Any R60 certified load cell according to Section 3.3.1.
Drawings:	Various

3.4.2 Bin, tank, and hopper load receptors

Construction in brief:	Load cell assemblies each consisting of a load cell stand assembly to support one of the mounting feet bin, tank or conveyor etc.
Reduction ratio:	1
Junction box:	Mounted in, on or near the dead load.
Load cell:	Any R60 certified load cell according to Section 3.2.1.
Drawings:	Various

3.5 Composition of modules

In case of composition of modules, EN 45501 paragraph 3.5 and 4.12 shall be satisfied.

3.6 Documents

The documents filed at DELTA (reference No. A530528) are valid for the weighing instruments described here.

4. Interfaces and peripheral equipment

4.1 Interfaces

One or more of the following interfaces may be incorporated. The interfaces are protective interfaces within the meaning of EN 45501 sect. 5.3.6.1 and need not to be secured.

4.1.1 Serial interface

Indicator can be equipped with up to three types of serial bidirectional interfaces. These interfaces can be RS 232, RS 422 / RS 485 and / or 20 mA CL ASCII. They are configurable as continuous, demand mode in ASCII or EPL, host mode, Modbus RTU according to the hardware, software options (if any) and the variant. Key functions can be performed via serial interfaces.

4.1.2 Printer interface

If any, serial interface and Ethernet can be used for printer connection.

4.1.3 Digital I/O interface

If the instrument has digital I/O board(s) and connected to external devices, the I/Os can be programmed to control them depending on weight values. The functioning of I/Os is convenient to the purpose of the variant. Key functions can be performed via inputs.

4.1.4 Ethernet interface

The Ethernet interface can be used for all available data output facilities of the instrument.

Key functions can be performed via Ethernet interface.

4.1.5 Profibus

Optionally, the indicator can be connected to the process controllers via profibus interface. The key functions can be performed via profibus interface.

4.1.6 Profinet

Optionally, the indicator can be connected to the process controllers via profinet interface. The key functions can be performed via profinet interface.

4.2 Peripheral equipment

Connection between the indicator and peripheral equipment shall be done by screened cables, except for the Ethernet cable.

The instrument may be connected to any simple peripheral device with a CE mark of conformity.

5. Approval conditions

5.1 The legal metrology parameter (par. 200) must be adjusted as 1

The parameter 200 of the instrument must be adjusted as 1 for usage of the instrument in approved applications.

5.2 Discontinuous totalisation is not approved.

Discontinuous total value is not approved for legal use. It may only be used for monitoring purposes.

5.3 Compatibility of modules

In case of composition of modules, WELMEC 2 (Issue 4) 2004, paragraph 11 shall be satisfied.

6. Special conditions for verification

6.1 Composition of modules

The environmental conditions should be taken into consideration by the composition of modules for a complete weighing instrument, for example instruments with load receptors placed outdoors and having no special protection against the weather.

The composition of modules shall agree with Section 5.3.

An example of a declaration of conformity document is shown in Section 10.

7. Securing and location of seals and verification marks

7.1 Securing and sealing

Seals shall bear the verification mark of a notified body according to ANNEX F of the Directive 2004/22/EC or alternative mark of the manufacturer according to ANNEX D of the Directive 2004/22/EC.

7.1.1 Indicator

Access to the calibration and changing legal metrologically relevant configuration parameters are achieved by the calibration jumper located on the main board. Sealing of this jumper can be done by sticker or lead wire seal.

The analogue load cell connector located on the main board must be sealed by sticker or lead wire seal.

Figures 2 to 4 indicate the sealing of BX3 indicator variants.

Data plate must be sealed by sticker as indicated in the sealing drawings if self destroyed label is not used.

7.1.2 Indicator - load cell connector - load receptor

Securing of the indicator, load receptor and load cell combined is done in one of the following ways:

- Sealing of the load cell connector with the indicator by a lead wire seal or brittle plastic stickers (as seen on the instrument's rear views in Figures 2 to 4).
- Inserting the serial number of the load receptor as part of the principal inscriptions contained on the indicator identification label
- Serial numbers of the load receptor and the indicator are the same.

7.1.3 Junction box for load cells

Access to the junction box for analogue load cells, if any, is prevented by the use of lead wire seals or by sealing it with brittle plastic stickers.

7.1.4 Peripheral interfaces

All peripheral interfaces are "protective". When the calibration jumper is sealed, they neither allow manipulation with weighing data or legal setup, nor change of the performance of the weighing instrument in any way that would alter the legality of the weighing.

7.2 Verification marks

A metrological M-sticker and a sticker with verification mark are to be placed on the identification plate of the instrument.

8. Location of CE mark of conformity and inscriptions

8.1 Identification plate

All inscriptions for the instrument shall be placed on the identification plate, which is located on the display module.

8.1.1 CE mark and metrological M

A CE mark of conformity and year of production grouped together with space for the metrological M shall be located on the identification plate.

8.1.2 Inscriptions

The identification plate shall bear the following inscriptions:

- Manufacturer's trademark and / or name
- Type designation
- Serial number
- Accuracy class
- Max, Minfill and d (these shall additional be duplicated near the display unless the description plate is located near the display)
- Temperature range: -10 / +40 °C
- Electromagnetic class: E2
- Humidity: Non-condensing
- Type examination certificate number

9. Pictures



BX 3 Desk Type



BX 3 Wall Type 1



BX 3 Wall Type 2



BX 3 with stand mount kit



BX 3 Stainless steel housing



BX 3 Panel Type

Figure 1. BX3 Indicator enclosures

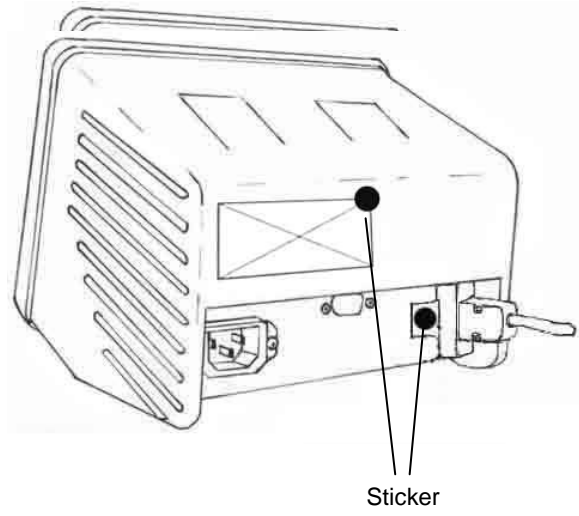
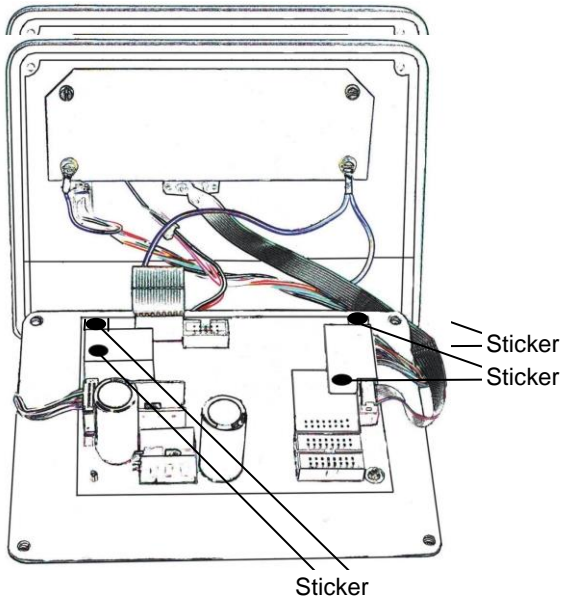

Sealing details with sticker

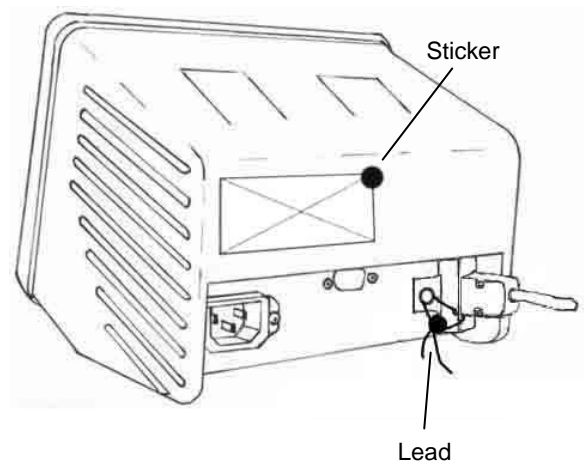
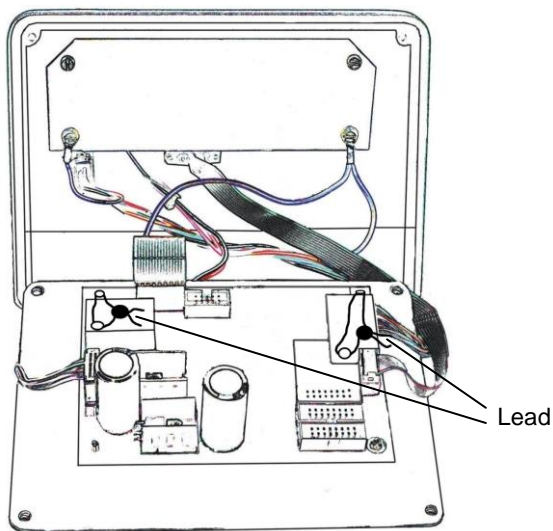

Sealing details with lead

Figure 2. BX3 aluminium housing sealing details

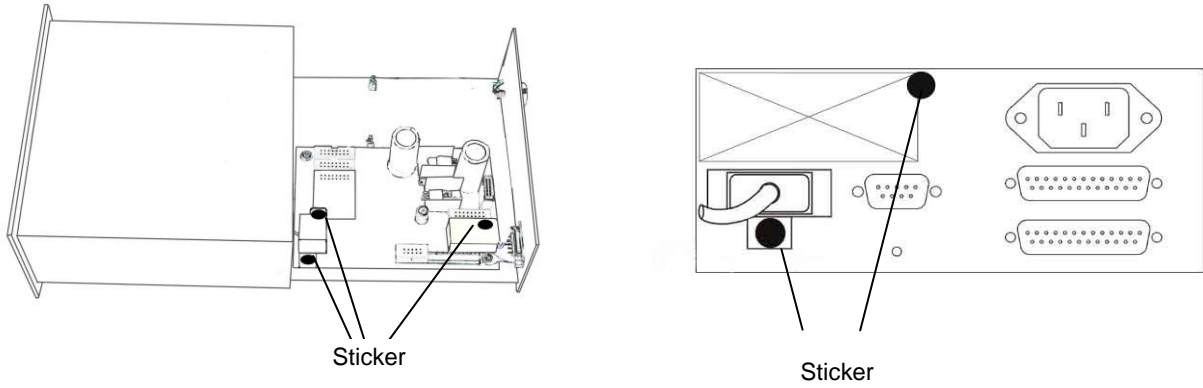

Sealing details with sticker

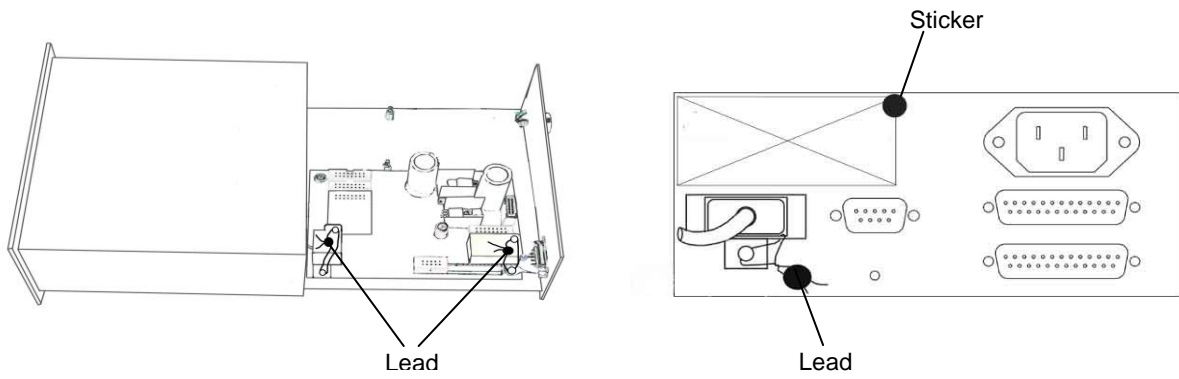

Sealing details with lead

Figure 3. BX3 panel type sealing details

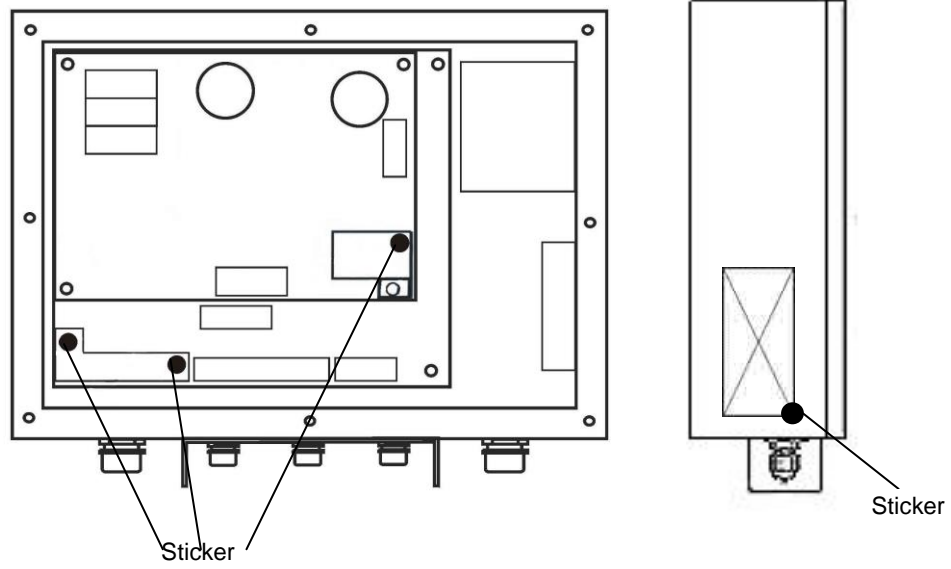

Sealing details with sticker

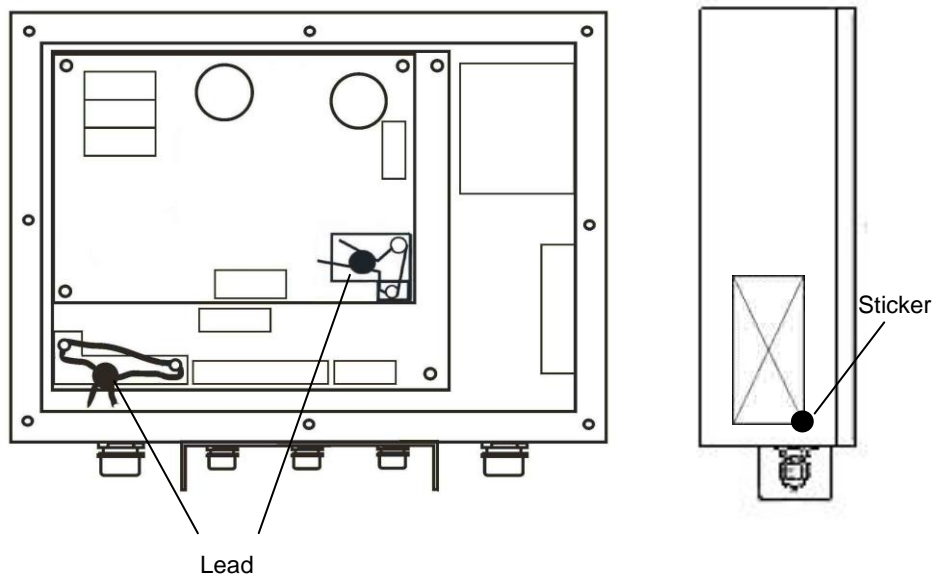

Sealing details with lead

Figure 4. BX3 stainless steel housing sealing details



Figure 5. Example of logo for front panel of indicator

10. Composition of modules – an example

COMPATIBILITY OF MODULES

Ref.: WELMEC 2

Non-Automatic Weighing Instrument, single-interval

Certificate of EU Type-Approval N°:

TAC: DK0199.446

INDICATOR

A/D (Module 1)

Type: BX3

Accuracy class according to EN 45501 and OIML R76:
Maximum number of verification scale intervals (n_{max}):
Fraction of maximum permissible error (mpe):
Load cell excitation voltage:
Minimum input-voltage per verification scale interval:
Minimum load cell impedance:
Coefficient of temperature of the span error:
Coefficient of resistance for the wires in the J-box cable:
Specific J-box cable-Length to the junction box for load cells:
Load cell interface:
Additive tare, if available:
Initial zero setting range:
Temperature range:
Test report (TR), Test Certificate (TC) or OIML Certificate of Conformity:

Class _{ind} (I, II, III or IIII)	III
n_{ind}	6000
p_1	0,5
U_{exc} [Vdc]	5
Δu_{min} [μV]	0,83
R_{Lmin} [Ω]	58
E_s [% / 25°C]	0,0044
S_x [% / Ω]	0,00335
$(L/A)_{max}$ [m / mm ²]	715
6-wire (remote sense)	
T^+ [% of Max]	0
IZSR [% of Max]	-10 / 10
T_{min} / T_{max} [°C]	-10 / 40

LOAD RECEPTOR

(Module 2)

Type: Platform

Construction:

Fraction of mpe:
Number of load cells:
Reduction ratio of the load transmitting device:
Dead load of load receptor:
Non uniform distribution of the load:
Correction factor:

(NUD = 0 is acceptable)

p_2	0,5
N	1
$R = F_M / F_L$	1
DL [% of Max]	20
NUD [% of Max]	0
$Q = 1 + (DL + T^+ + IZSR + NUD) / 100$	1,3

LOAD CELL

ANALOG (Module 3)

Type: Tedeia 1042

Accuracy class according to OIML R60:
Maximum number of load cell intervals:
Fraction of mpe:
Rated output (sensitivity):
Input resistance of single load cell:
Minimum load cell verification interval: ($v_{min\%} = 100 / Y$)
Rated capacity:
Minimum dead load, relative:
Temperature range:
Test report (TR) or Test Certificate (TC/OIML) as appropriate:

Class _{LC} (A, B, C or D)	C
n_{LC}	3000
p_3	0,7
C [mV / V]	2
R_{LC} [Ω]	350
$v_{min\%}$ [% of E_{max}]	0,00667
E_{max} [kg]	10
$(E_{min} / E_{max}) * 100$ [%]	0
T_{min} / T_{max} [°C]	-10 / 40

TC2949 rev.4

COMPLETE WEIGHING INSTRUMENT

Single-interval

Manufacturer: AFM

Type: BX3 aut. gravimetric filling instr.

Accuracy class according to EN 45501 and OIML R76:
Fractions: $p_1 = p_1^2 + p_2^2 + p_3^2$:
Maximum capacity:
Number of verification scale intervals:
Verification scale interval:
Utilisation ratio of the load cell:
Input voltage (from the load cells):
Cross-section of each wire in the J-box cable:
J-box cable-Length:
Temperature range to be marked on the instrument:
Peripheral Equipment subject to legal control:

Class _{WI} (I, II, III or IIII)	III
p_i	1,0
Max [kg]	3
n	3000
e [kg]	0,001
$\alpha = (Max / E_{max}) * (R / N)$	0,30
$\Delta u = C * U_{exc} * \alpha * 1000 / n$ [$\mu V/e$]	1,00
A [mm ²]	0,22
L [m]	0
T_{min} / T_{max} [°C]	Not required

Acceptance criteria for compatibility		Passed, provided no result below is < 0	
Class _{WI}	\leq Class _{ind} & Class _{LC} (WELMEC 2: 1)	Class _{WI}	PASSED
p_i	\leq 1 (R76: 3.5.4.1)	1 - p_i	0,0
n	\leq n_{max} for the class (R76: 3.2)	n_{max} for the class - n	7000
n	\leq n_{ind} (WELMEC 2: 4)	n_{ind} - n	3000
n	\leq n_{LC} (R76: 4.12.2)	n_{LC} - n	0
E_{min}	\leq DL * R / N (WELMEC 2: 6d)	(DL * R / N) - E_{min}	0,6
$v_{min} * \sqrt{N} / R$	\leq e (R76: 4.12.3)	$e - (v_{min} * \sqrt{N} / R)$	0,000
or (if v_{min} is not given)		Alternative solutions:	$\uparrow \downarrow$
$(E_{max} / n_{LC}) * (\sqrt{N} / R)$	\leq e (WELMEC 2: 7)	$e - ((E_{max} / n_{LC}) * (\sqrt{N} / R))$	
Δu_{min}	\leq Δu (WELMEC 2: 8)	$\Delta u - \Delta u_{min}$	0,17
R_{Lmin}	\leq R_{LC} / N (WELMEC 2: 9)	$(R_{LC} / N) - R_{Lmin}$	292
L / A	\leq (L / A) _{max} ^{WI} (WELMEC 2: 10)	$(L / A)_{max}^{WI} - (L / A)$	1819
T_{range}	\leq $T_{max} - T_{min}$ (R76: 3.9.2.2)	$(T_{max} - T_{min}) - T_{range}$	20
$Q * Max * R / N$	\leq E_{max} (R76: 4.12.1)	$E_{max} - (Q * Max * R / N)$	6,1

Signature and date:

Conclusion PASSED

This is an authentic document made from the program:
"Compatibility of NAWI-modules version 3.2".

