



EU Type Examination Certificate

No. DK0199.551

ECS..

AUTOMATIC CATCHWEIGHING INSTRUMENT

Issued by DELTA
EU - Notified Body No. 0199

In accordance with the requirements for the automatic weighing instrument of Directive 2014/32/EU of the European Parliament and Council on Measuring Instruments (MID).

Issued to Kosan Crisplant A/S
P. O. Pedersensvej 22
8200 Aarhus N
Denmark

In respect of Automatic catchweighing instrument designated ECS.. with variants of modules of load receptors, load cells and peripheral equipment.
Accuracy class XIII(1) and Y(a).
Maximum capacity, Max: From 30 kg up to 600 kg.
Verification scale interval: $e = \text{Max} / n$.
Maximum number of verification scale intervals: $n = 3000$ (however dependent on environment and the composition of the modules).
Variants of modules and conditions for the composition of the modules are set out in the annex.

The conformity with the essential requirements in Annex 1 and the specific requirements in Annex VIII, chapter I & II of the Directive 2014/32/EU is met by the application of OIML R51-1:2006, OIML D11:2013 with severity level 3, WELMEC Guide 7.2:2015, and WELMEC Guide 8.16-1:2013.

The principal characteristics and approval conditions are set out in the descriptive annex to this certificate.

The annex comprises 14 pages.

Issued on 2017-01-01
Valid until 2027-01-01

Signatory: J. Hovgård

DELTA
Venlighedsvej 4
2970 Hørsholm
Denmark

Tel. +45 72 19 40 00
Fax +45 72 19 40 01
www.delta.dk
VAT No. DK 55117314

Descriptive annex

Contents	Page
1. Name and type of instrument and modules	2
2. Description of the construction and function	2
2.1 Construction	2
2.2 Functions	4
3. Technical data	5
3.1 ECS.. Automatic weighing instrument	5
3.2 Display and A / D modules	5
3.3 Load cells	6
3.4 Load receptors	6
3.5 Composition of modules	6
4. Interfaces and peripheral equipment	7
4.1 Interfaces	7
4.2 Peripheral equipment	7
5. Approval conditions	7
5.1 Connection of cables	7
5.2 Compatibility of modules	7
6. Special conditions for verification	7
6.1 Composition of modules	7
7. Securing and location of seals and verification marks	8
7.1 Securing and sealing	8
7.2 Verification marks	8
8. Location of CE mark of conformity and inscriptions	8
8.1 Identification plate	8
9. Pictures	9
10. Composition of modules – illustrated	14

1. Name and type of instrument and modules

The automatic weighing instrument is designated ECS and is intended for the weighing of LPG cylinders. It consists of a control unit (CUC-Ex Mrk III), an A/D module (load cell module) and a separate load receptor.

The automatic weighing instrument is available in various models as follows:

ECSxxx Check Weigher

ECSxxx Filling Machine

ECSxxx Weight Correction Machine

where xxx designate the capacity of the automatic weighing instrument.

In the description, the display and control module is referenced as CUC. The instrument is a self-indicating weighing instrument with single-interval. The instrument is powered from an external AC mains power supply that also contains a serial interface or optionally powered by battery. The serial interface gives an interface to peripheral equipment such as a PC. The system is for use in hazardous areas.

The modules appear from Sections 3.1, 3.2 and 3.3; the principle of the composition of the modules is set out in Sections 6.1 and 10.

2. Description of the construction and function

2.1 Construction

2.1.1 CUC (display/control module)

The module is specified in Section 3.1.

Enclosures and keyboard

The CUC module is housed in a plastic enclosure 125 mm wide, 245 mm high and 90 mm deep. It is designed primarily for industrial use but may also be used in an office environment. This enclosure is designed to meet an IP 65 rating and can be exposed to water and dust.

The front panel of the CUC module comprises:

- A LCD display with five digits for weighing indication, several smaller digits for setup and information messages and appropriate status indicators.
- A keyboard contains 16 gold cross point keys used to enter commands or data to the weight indicator. Each key is identified with a name and / or pictograph.

The bottom of the enclosure contains the following:

- A power / communication cord attached to the instrument via a gland connector.
- A load cell module cord attached to the instrument via a gland connector.
- A gland connector for cable to digital inputs.
- A gland connector for cable to digital outputs.

Electronics

The CUC is an intrinsically safe device that includes a microprocessor control circuitry, keyboard, volatile and non-volatile memory. The function of the CUC is to control the instrument and to receive the digitized representation of the load cell signal from the A / D module and convert it to a digital represented weight and show it in the display.

A part of the non-volatile memory in the CUC is reserved for storage of the weight and calibration data and software functions that are under legal metrology control. This part of the instrument software is protected and can only be changed if instrument is unlocked. The software part of this area is designated version: LCM 101xx.

2.1.2 A / D-module (load cell module)

The A / D-module is housed in an aluminium enclosure 80 mm wide, 75 mm high and 60 mm deep. This enclosure is designed to meet an IP 66 rating and can be exposed to water and dust.

The side of the enclosure contains the following:

- An 8 pin male connector for connecting the CUC module cord.
- A gland connector for access to the load cell input terminal block located inside the enclosure.



Electronics

The A / D module comprises an analogue to digital conversion circuitry, a 4 wire interface for the load cell input and a serial interface to the CUC within a single enclosure.

The function of the A/D module is to convert the load cell signal into a digitized representation and send the value to the CUC. Conversion of the digitized value into a weight representation is controlled by the CUC and the legal software part.

2.1.3 External power supply / junction box

The external power supply is a universal switching type and can accept an input voltage from the power mains from 85 - 264 VAC 50 or 60 Hz. The indicator produces a supply voltage of 5 VDC for the LCM when powered from the power mains or, if configured for battery operation.

When the instrument is powered from the universal external power supply, a junction box is inserted between the instrument and power supply box.

The power supply includes an interface to a bi-directional RS485 serial interface.

2.1.4 Load receptor

Set out in Section 3.3

2.1.5 Interfaces and peripheral equipment

Set out in Section 4.

2.2 Functions

2.2.1 Functions and devices

The automatic weighing instrument has the following permitted functions and devices that are subject to the Measuring Instrument Directive:

- Initial zero setting device (max. 20 % of Max)
- Semiautomatic zero setting device
- Zero tracking device
- Automatic zero setting device
- Preset tare device
- Storing preset tare
- Toggling between Gross and Net when tare operation is activated
- Extended indicating device (service mode only)
- Optional battery operation

2.2.2 Software

The instrument name and software version is displayed during the power up sequence of the instrument.

Name: XXYY, where XX can be:

- CS for Check weigher
- FS for Filling machine
- AS for Weight correction machine
- OT for Outlet with Check weigher

and YY can be 01 to 20.

The versions of the software in conformity with the Directive are,

For the CUC: 3.xx.yy

For the LCM: 1.01.zz

xx, yy and zz can be numbers between 01 and 99 and represents non-legal parts of the softwares.

The version numbers can be displayed upon request. Refer to instrument user guide.

The non-volatile memory of the LCM module holds a serial number and an incremental event counter number.

S/N [YYMMDD-XXXX]

where YY=year, MM=month, DD=date followed by a number in succession.

EVT CNT [kkkkk] is the LCM event counter value. The counter is a non-resettable value that increments once each time special operational mode of the weighing instrument is entered and one or more changes are made to the configuration of the legal parameters of the weighing instrument.

Software versions and event counter value are noted on a brittle plastic sticker close to the identification plate.

3. Technical data

The automatic weighing instruments and its modules are set out as follows:

3.1 ECS.. Automatic weighing instrument

Type:	ECS..
Accuracy class:	XIII(1) and Y(a)
Maximum capacity (Max):	$30 \text{ kg} \leq \text{Max} \leq 600 \text{ kg}$
Minimum capacity (Min):	$\geq 20 e$
Verification scale interval (e):	$e \geq 0.01 \text{ kg}$ and $e \geq \text{Max} / n$
Weighing range:	Single-interval
Maximum number of Verification Scale Intervals (n):	3000
Maximum tare effect:	$\leq 100 \% \text{ of Max}$
Temperature range:	$-10^\circ \text{ to } 50^\circ \text{ C}$
Weighing mode:	Static or dynamic
Conveyor speed:	$\leq 30 \text{ m/minute}$
Automatic zero setting:	min. each 44th minute
Electromagnetic class:	E2
Humidity:	Non-condensing

3.2 Display and A / D modules

The HMI / CTRL has the following characteristics:

Type:	CUC-Ex MKIII
Temperature range:	$-10^\circ \text{ to } 55^\circ \text{ C}$
Accuracy class:	III
Weighing range:	Single-interval
Maximum number of Verification Scale Intervals:	3000 (class III)
Internal resolution:	$> 30,000 \text{ counts}$
Maximum tare effect:	Max within display limits
Fractional factor:	$\pi = 0.5$
Minimum input-voltage per VSI:	$1 \mu\text{V}$
Minimum signal voltage for dead load:	1 mV
Excitation voltage:	5 Vdc
Analogue range:	$0 \text{ to } 10 \text{ mV}$
Circuit for remote sense:	None
Minimum input-impedance:	350 ohm
Maximum input-impedance:	1200 ohm
External mains power supply:	$85 - 264 \text{ Vac}$ (50 / 60 Hz) or 12 Vdc battery
Peripheral interface:	Set out in Section 4

3.2.1 Connecting cable between the A / D module and load cell

Line:	4 wires (no sense), shielded
Maximum length:	The certified length of the load cell cable

3.3 Load cells

The load receptors are designed for fix mounting.

3.3.1 General acceptance of modules

Any load cell(s) may be used for instruments under this type examination certificate provided the following conditions are met:

- 1) There is a respective Part, Evaluation or Test certificate (EN 45501) or an OIML Certificate of Conformity (R60) issued for the load cell by a Notified Body responsible for type examination under the Directive 2014/31/EU.
- 2) The certificate contains the load cell types and the necessary load cell data required for the manufacturer's declaration of compatibility of modules (WELMEC 2:2015), and any particular installation requirements. A load cell marked NH is allowed only if humidity testing to EN 45501 has been conducted on this load cell.
- 3) The compatibility of load cells and indicator is established by the manufacturer by means of the compatibility of modules form, contained in the above WELMEC 2 document, or the like, at the time of EU verification or declaration of EU conformity of type.
- 4) The load transmission must conform to one of the examples shown in the WELMEC 2.4 Guide for load cells.

3.3.2 Load cells

The load cells, which are listed below are certified as modules in the weighing instrument.

Manufacturer	Load cell type
Flintec	PC6

3.4 Load receptors

The following types of load receptors are approved for the automatic weighing instrument:

- Platform with chain conveyor for dynamic or static weighing
- Platform with roller conveyor for static weighing
- Platform with lift table for static weighing
- Platform for static weighing

3.5 Composition of modules

In case of composition of modules, EN 45501:2015, Annex F shall be satisfied.

4. Interfaces and peripheral equipment

4.1 Interfaces

The interfaces are characterised "Protective interfaces" according to paragraph 8.4 in the Directive.

4.1.1 Load cell interface

A 4-terminal connector for the load cell is positioned on A/D module circuit board and is accessed through a gland connector on the load cell module enclosure.

4.1.2 Power supply / junction box

The power supply includes electronics to convert the main power supply to appropriate supply voltage for the weighing system.

The junction box includes connectors for distributing the supply voltage. Figure 1 shows an example of one particular configuration of the weighing equipment.

4.1.3 Serial I/O Interface

The serial connection to the CUC-Ex is always done through the power supply which has a RS485 channel.

A 2-terminal connector providing the bi-directional RS485 compatible interface is positioned on the power supply and is accessed through a gland connector on the side panel of the instrument enclosure.

4.2 Peripheral equipment

Connection between the indicator and peripheral equipment is allowed by screened cable.

The instrument may be connected to any simple recipient printer with a CE mark of conformity.

5. Approval conditions

5.1 Connection of cables

All cables shall be shielded, and the shield shall be properly EMC wise connected to the housing / connector in both ends.

5.2 Compatibility of modules

In case of composition of modules, EN45501:2015, annex F shall be satisfied.

6. Special conditions for verification

6.1 Composition of modules

The environmental conditions should be taken into consideration by the composition of modules for a complete weighing instrument, for example instruments with load receptors placed outdoors and having no special protection against the weather.

The composition of modules shall agree with Section 5.2.

An example of a declaration of conformity document is shown in Section 10.

7. Securing and location of seals and verification marks

7.1 Securing and sealing

Seals shall bear the verification mark of a notified body according to ANNEX II, module D or F of the Directive 2014/32/EU.

7.1.1 Mechanical sealing

The identification plate shall be secured against removal with a brittle plastic sticker.

7.2 Verification marks

A sticker with verification marks are to be placed on the data plate of the instrument.

8. Location of CE mark of conformity and inscriptions

8.1 Identification plate

All inscriptions for the instrument shall be placed on the identification plate, which is located on the display module.

8.1.1 CE mark

CE mark and supplementary metrological marking shall be applied to the indicator according to article 21 of Directive 2014/32/EU.

8.1.2 Inscriptions

The identification plate shall bear the following inscriptions:

- Manufacturer's trademark and / or name
- Manufacturer's postal address.
- Type designation
- Serial number
- Max, Min and e (these shall additional be duplicated near the display unless the description plate is located near the display)
- Type examination certificate number
- Event counter
- Software versions
- Temperature range: -10 / +50 °C
- Electromagnetic class: E2
- Humidity: Non-condensing
- Type examination certificate number

9. Pictures

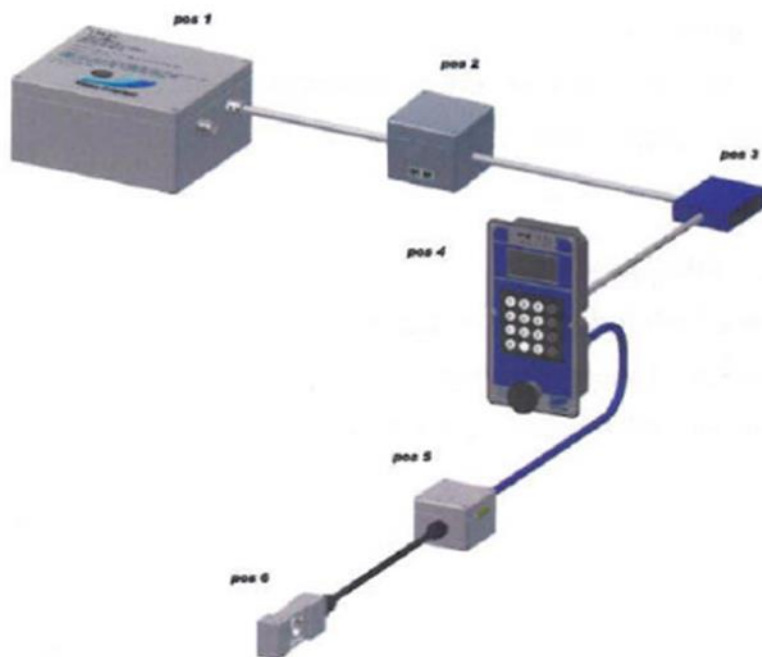

Figure 1 The basic modules of ECS..

- pos.1: CPI power supply
- pos.2: Connection box
- pos.3: T-connection box (optional)
- pos.4: CUC
- pos.5: LCM module
- pos.6: Load cell/load receptor

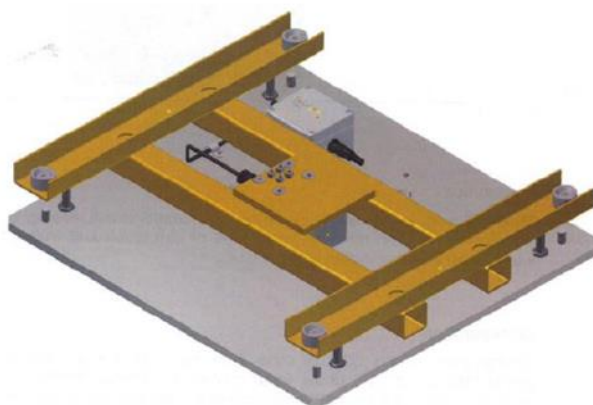

Figure 2 Load receptor

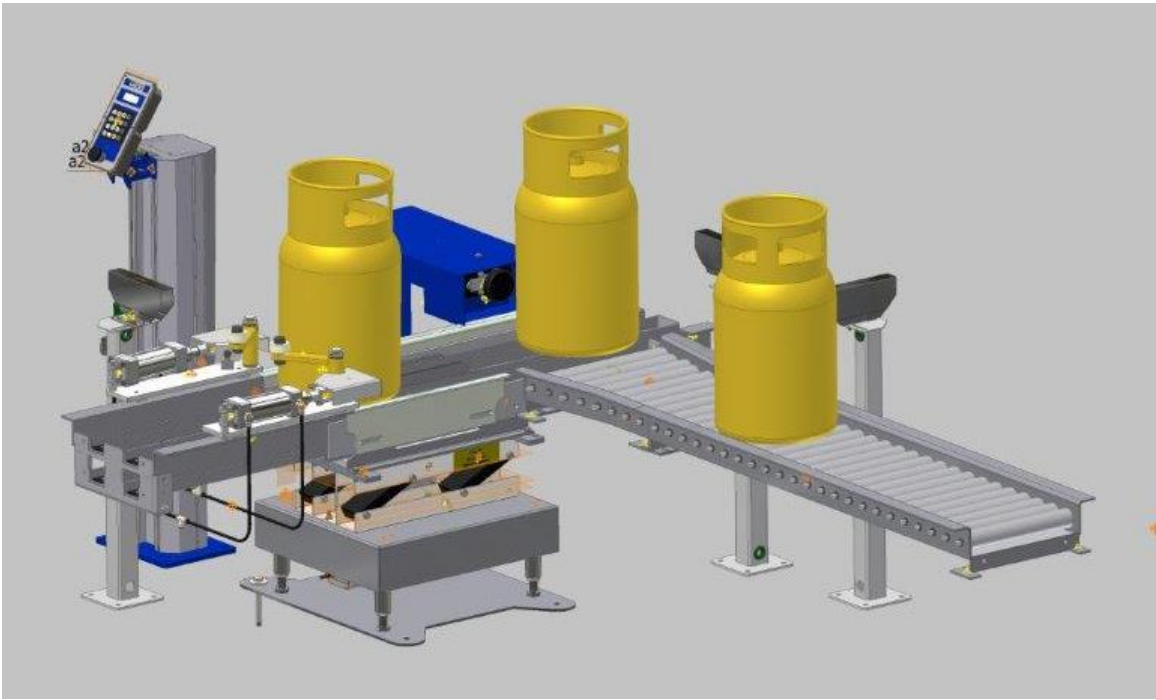

Figure 3 ECS Check Weighing with static lifting table

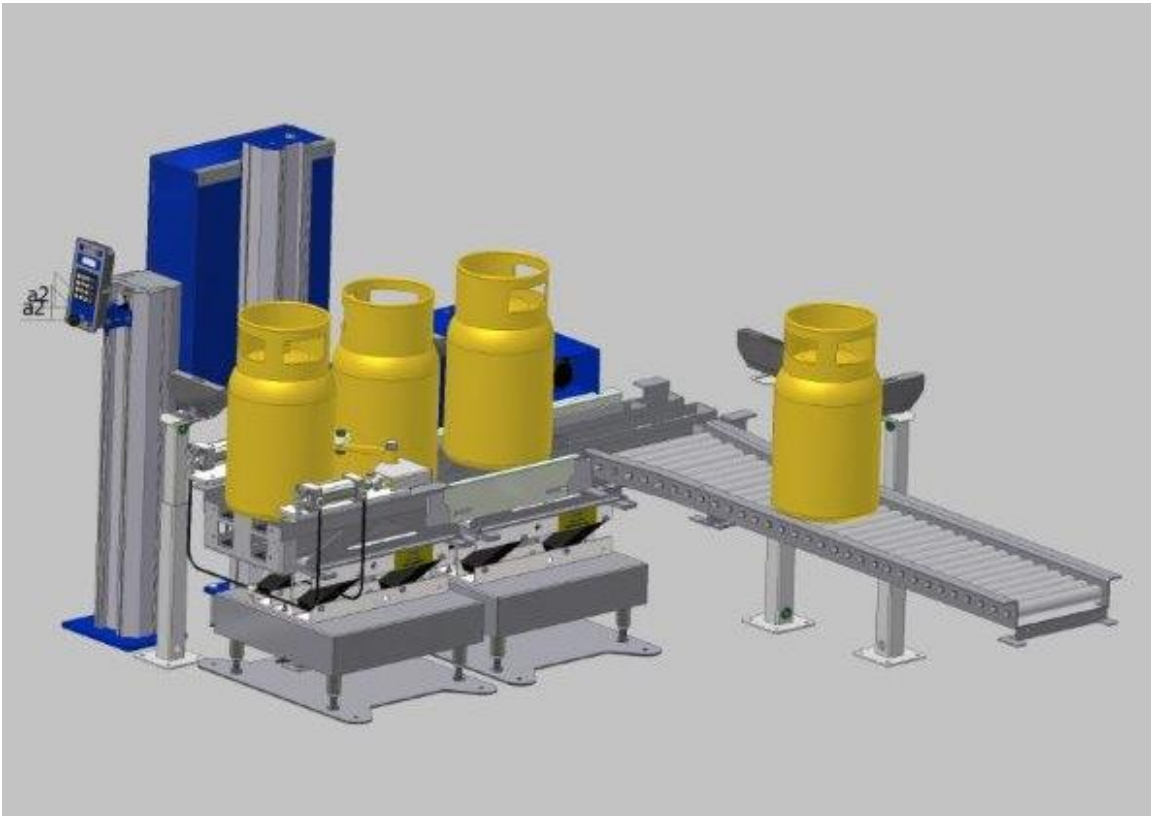

Figure 4 ECS Check weighing with double static lifting table

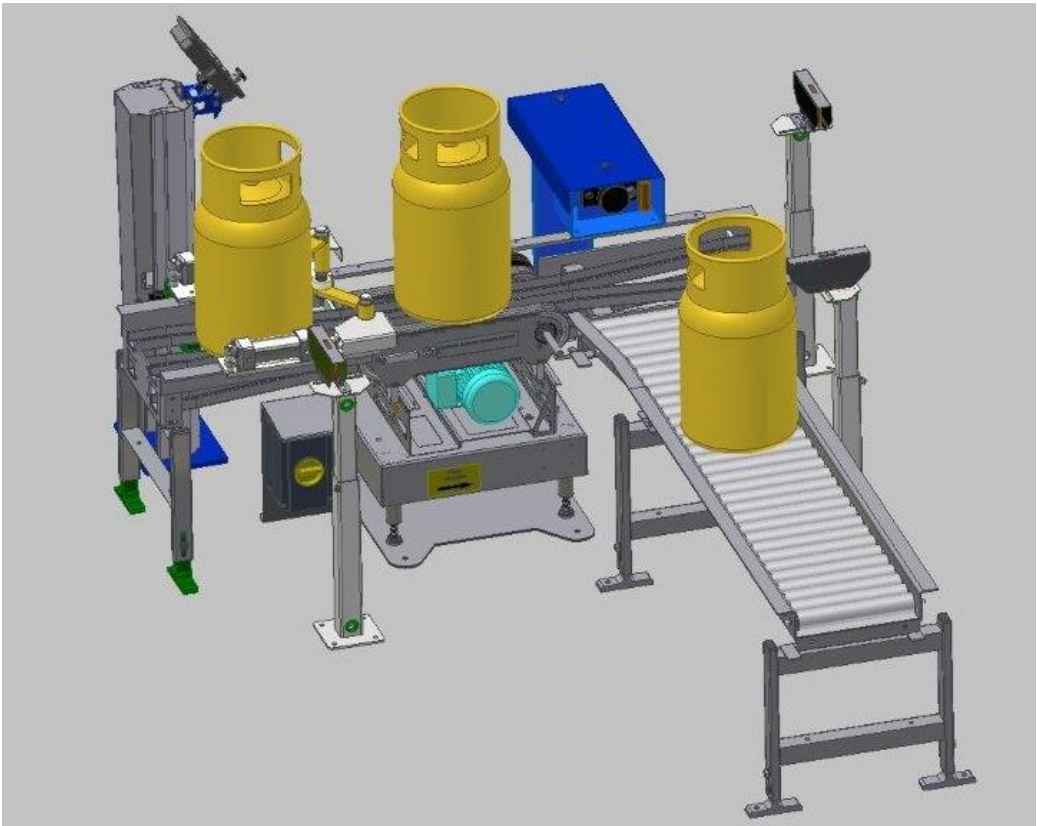

Figure 5 ECS check weighing with dynamic table

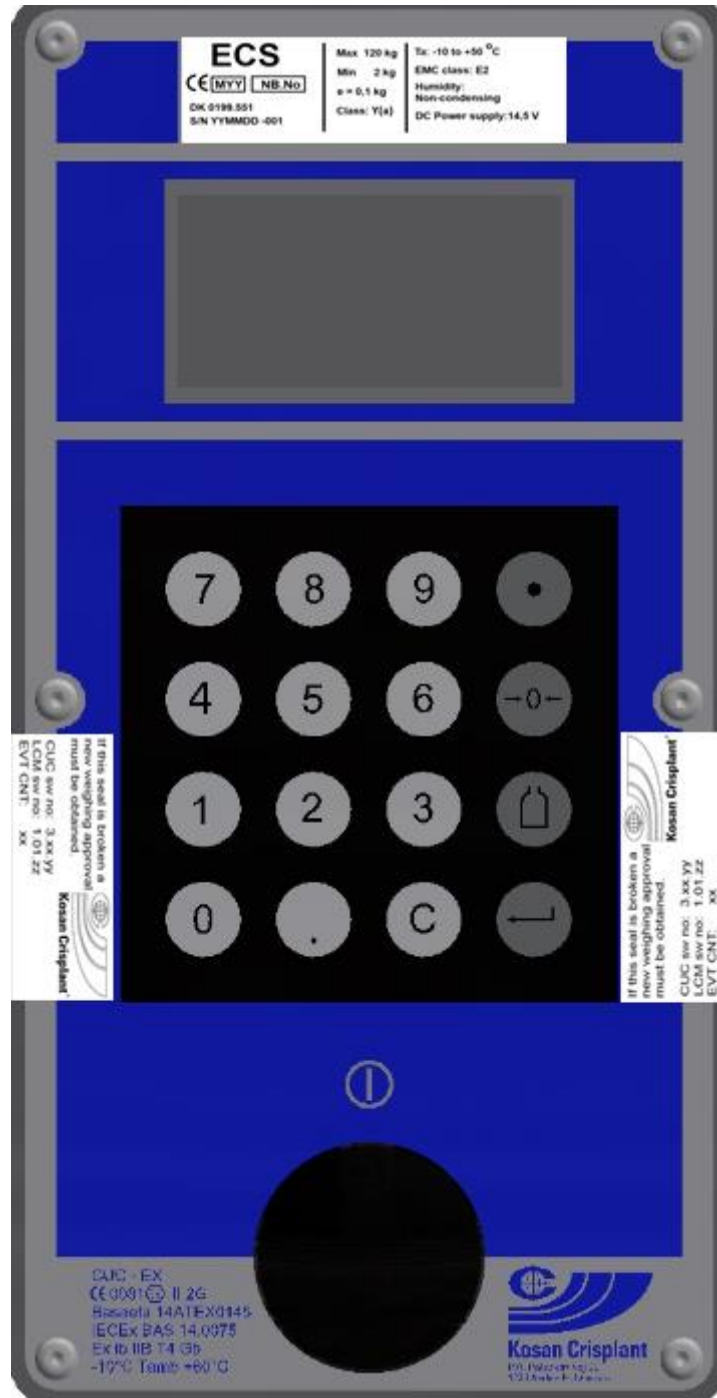

Figure 6 CUC module including sealing



Figure 7 Sealing of the AD-module

10. Composition of modules – illustrated

COMPATIBILITY OF MODULES

Ref.: OIML R76-1:2006

Non-Automatic Weighing Instrument, single-interval.

Copy module data

Certificate of EU Type-Approval N°:

TAC: DK0199.551

INDICATOR

A/D (Module 1)

Type: CUC Ex MKIII

Accuracy class according to EN 45501 and OIML R76:
Maximum number of verification scale intervals (n_{max}):
Fraction of maximum permissible error (mpe):
Load cell excitation voltage:
Minimum input-voltage per verification scale interval:
Minimum load cell impedance:
Maximum load cell impedance:
Number of A/D-channels used:
Coefficient of temperature of the span error:
Coefficient of resistance for the wires in the J-box cable:
Specific J-box cable-Length to the junction box for load cells:
Load cell interface:
Additive tare, if available:
Initial zero setting range:
Temperature range:
Test report (TR), Test Certificate (TC) or OIML Certificate of Conformity:

ClassInd (I, II, III or IIII)	III	
n _{ind}	3000	
p1	0.5	
U _{exc} [Vdc]	5	
ΔU _{min} [μV]	1	
RL _{min} [Ω]	350	
RL _{max} [Ω]	350	
K	1	
Es [% / 25°C]		
Sx [% / Ω]		
(L/A) _{max} [m / mm ²]	10	
6-wire (remote sense)		
T ⁺ [% of Max]	0	
IZSR [% of Max]	-10 / 10	
T _{min} / T _{max} [°C]	-10 / 50	

LOAD RECEPTOR

(Module 2)

Type: CUC Ex MKIII

Construction:
Fraction of mpe:
Number of load cells:
Number of load cells per A/D-channel, min and max value:
Reduction ratio of the load transmitting device:
Dead load of load receptor:
Non uniform distribution of the load: (NUD = 0 is acceptable)
Correction factor: Q = 1 + (DL + T⁺ + IZSR + NUD) / 100

Platform		
p2	0.5	
N	1	
N _{ch_min} & N _{ch_max}	1 / 1	
R = F _M / F _L	1	
DL [% of Max]	25	
NUD [% of Max]	20	
Q = 1 + (DL + T ⁺ + IZSR + NUD) / 100	1.55	

LOAD CELL

ANALOG (Module 3)

Type: Flintec PC6

Accuracy class according to OIML R60:
Maximum number of load cell intervals:
Fraction of mpe:
Rated output (sensitivity):
Input resistance of single load cell:
Minimum load cell verification interval: (v_{min}% = 100 / Y)
Rated capacity:
Minimum dead load, relative: (E_{min} / E_{max}) * 100
Minimum dead load output return: (DR% = 50 / Z)
Temperature range:
Test report (TR) or Test Certificate (TC/OIML) as appropriate:

ClassLC (A, B, C or D)	C	
nLC	3000	
p3	0.7	
C [mV / V]	2	
RLC [Ω]	350	
v _{min} % [% of E _{max}]	0.01	
E _{max} [kg]	200	
(E _{min} / E _{max}) * 100 [%]	0	
DR% [% of E _{max}]		
T _{min} / T _{max} [°C]	-10 / 50	
D09-00.02		

COMPLETE WEIGHING INSTRUMENT

Single-interval

Manufacturer: Kosan Crisplant A/S

Type: ECS

Accuracy class according to EN 45501 and OIML R76:
Fractions: p_i = p₁² + p₂² + p₃²:
Maximum capacity:
Number of verification scale intervals:
Verification scale interval:
Utilisation ratio of the load cell:
Input voltage (from the load cells):
Cross-section of each wire in the J-box cable:
J-box cable-Length:
Temperature range to be marked on the instrument: Not required
Peripheral Equipment subject to legal control:

Class ^{wI} (I, II, III or IIII)	III	
p _i	1.0	
Max [kg]	60	
n	3000	
e [kg]	0.02	
α = (Max / E _{max}) * (R / N)	0.30	
Δu = C * U _{exc} * α * 1000 / n [μV/e]	1.00	
A [mm ²]	0.5	
L [m]	5	
T _{min} / T _{max} [°C]		

Acceptance criteria for compatibility	Passed, provided no result below is < 0
Class ^{wI} <= ClassInd & ClassLC (R76: F.4 (1))	Class ^{wI} : PASSED
p _i <= 1 (R76: 3.10.2.1)	1 - p _i = 0.0
n <= n _{max} for the class (R76: 3.2)	n _{max} for the class - n = 7000
n <= n _{ind} (R76: F.4 (4))	n _{ind} - n = 0
n <= nLC (R76: F.2.6)	nLC - n = 0
E _{min} <= DL * R / N (R76: F.2.5)	(DL * R / N) - E _{min} = 15
v _{min} * √N / R <= e (R76: F.2.7)	e - (v _{min} * √N / R) = 0.000
or (if v _{min} is not given)	Alternative solutions: ↑ ↓
(E _{max} / nLC) * (√N / R) <= e (R76: F.4 (7))	e - ((E _{max} / nLC) * (√N / R)) =
ΔU _{min} <= Δu (R76: F.4 (8))	Δu - ΔU _{min} = 0.00
RL _{min} <= RLC / N (R76: F.4 (9))	(RLC / N _{ch_max}) - RL _{min} = 0
RL _{max} >= RLC / N (R76: F.4 (9))	RL _{max} - (RLC / N _{ch_min}) = 0
L / A <= (L / A) _{max} ^{wI} (R76: F.4 (10))	(L / A) _{max} ^{wI} - (L / A) = 0
T _{range} <= T _{max} - T _{min} (R76: 3.9.2.2)	(T _{max} - T _{min}) - T _{range} = 20
Q * Max * R / N <= E _{max} (R76: F.2.4)	E _{max} - (Q * Max * R / N) = 107.0

Signature and date:

Conclusion PASSED

This is an authentic document made from the program:
"Compatibility of NAWI-modules version 4.0".