



We help ideas meet the real world

EVALUATION CERTIFICATE

No. DK0199-R61-09.03 Revision 1

Object name FT-13

Object type Weighing controller for automatic gravimetric filling instrument

Issued by DELTA Danish Electronics, Light & Acoustics

In accordance with OIML R61:2004,
OIML D11:2004 section 12 and 13 with severity level 3
WELMEC Guide 7.2:2009, and
WELMEC Guide 8.8:2008.

Issued to **Flintec GmbH**
Bemannsbruch 9
74909 Meckesheim
Germany

Manufacturer **Flintec GmbH**

Characteristics A weighing indicator suitable for control of an automatic gravimetric filling instrument.

Description and documentation The weighing indicator is described and documented in the annex to this certificate.

Remarks Summary of tests involved: see annex.

This evaluation certificate cannot be quoted in an EU type examination certificate without permission of the holder of the certificate mentioned above.

The annex comprises 15 pages.

Issued on 2010-04-13

Signatory: J. Hovgård

DELTA
Danish Electronics,
Light & Acoustics
Venlighedsvej 4
2970 Hørsholm
Denmark
Tel. (+45) 72 19 40 00
Fax (+45) 72 19 40 01
www.delta.dk
VAT No. DK 12275110

Descriptive annex

Contents		Page
1.	Name and type of instrument and modules	2
2.	Description of the construction and function	2
2.1	Construction	2
2.2	Functions	2
3.	Technical data	6
3.1	FT-13 based automatic gravimetric filling instrument	6
3.2	Indicator	7
3.3	Load cells	8
3.4	Load receptors	8
3.5	Composition of modules	8
4.	Interfaces and peripheral equipment	9
4.1	Interfaces	9
4.2	Peripheral equipment	9
5.	Approval conditions	10
5.1	The legal metrology parameter (par. 200) must be adjusted as 1	10
5.2	Discontinuous totalisation is not approved.	10
6.	Special conditions for verification	10
7.	Securing and sealing of FT-13 indicator	10
7.1	Indicator	10
7.2	Peripheral interfaces	10
8.	Tests performed	11
9.	Documentation	11
10.	Pictures	12

1. Name and type of instrument and modules

The self-indicating electronic weighing indicator designated FT-13 is a weighing controller for an automatic gravimetric filling instrument. It can be connected to a separate load receptor and peripheral equipment such as printers or other devices, as appropriate.

2. Description of the construction and function

2.1 Construction

2.1.1 FT-13 weighing indicator.

The FT-13 indicator consists of analogue to digital conversion, microprocessor control circuitry, power supply, keyboard, non-volatile memory for storage of calibration and weight data, option boards and a weight display contained within a single enclosure.

FT-13 indicator can be supplied either in desk type enclosure, stainless steel enclosure or panel type enclosure.

The obtainable specifications for a FT-13 controlled automatic gravimetric filling instrument is specified in Section 3.1.

The FT-13 indicator is specified in Section 3.2.

2.1.2 Load cells

Requirements to connected load cell(s) are set out in Section 3.3.

2.1.3 Load receptor

Requirements to connected load receptor are set out in Section 3.4.

2.1.4 Interfaces and peripheral equipment

Set out in Section 4.

2.2 Functions

The weighing indicator is microcontroller based electronics that requires the external connection of strain gauge based analogue load cells. The weight information appears in the digital display located on the front of the instrument and may be transmitted to peripheral equipment for recording, processing or display. There are available data output options such as binary data output, analogue output, Modbus, Ethernet etc.

The primary functions provided are detailed below. The key functions can be provided via opto-isolated inputs, serial interfaces, Modbus RTU, profibus, profinet and / or Ethernet .

The main functions are described below.

2.2.1 Power up

For legal metrological applications, on power up the indicator performs an automatic self test and verification of all data storage components to ensure correctness of instruction, calibration and data memory.

During the self test the following are displayed in sequence:

Variant name together with software version number and installed options for 10 seconds. All digits and later annunciators are illuminated for a short period of time and all digits counting up for a period of time.

In case of error, appropriate error messages are given.

After the test, the indicator will precede with initial zero setting, if this function is activated. The message [E E E] will remain in the display until pressing enter key for values out of initial zeroing range; but power on zero device do not perform its function in this case.

2.2.2 Test function

On power up the indicator will test all memory functions and cause all display elements to illuminate so that a visual verification of their operation can be made.

In case of error, appropriate error messages are given.

Serial data output port and digital I/O's can be tested via keypad in test mode.

2.2.3 Displayed range

The indicator displays from -2 % of Max (minus zeroing range) to Max + 9e.

Under this range, the message “under“ appears on the display.

Over this displaying range, the message “over” appears on the display.

If the input signal is out of the instrument input conversion range “ADC OUT” message appears.

2.2.4 Zero setting

Zero setting can only take place when the weight display is stable.

Pressing the ZERO key causes a new zero reference to be established and the ZERO annunciator to be illuminated at the centre of zero.

2.2.5 Automatic zero setting

Zero setting may take place during filling process, if programmed. The zero setting conditions are applied here.

2.2.6 Increased display resolution (in weighing mode)

The weight indicator is equipped with increased resolution which operates after pressing the related key and functioning shorter than 5 seconds. It is not possible to get print out in increased resolution.

2.2.7 Tare device

The FT-13 is equipped with a subtractive tare device, whereby the maximum tare capacity corresponds to the maximum indication of the scale. The condition for a taring is the equilibrium of the scale and positive indication. The status tared is marked by the symbol “Net” on the display. Repeated pressing causes the tare to be cleared and new tare entered in its place.

The indicator FT-13 tare device can be working in automation, like filling, depending on the application.

2.2.8 Automatic tare device

Tare setting may take place during filling process, if programmed. All tare device conditions are applied in this device.

2.2.9 Target (Preset) value device

Value, expressed in units of mass, preset by the operator by means of the fill setting device, in order to define the nominal value of the fills.

2.2.10 Pre-act adjustment device

The setting of the fine feed cut-off value may be supplemented for minimising the filling deviation.

2.2.11 Zeroing period

The zeroing is performed automatically at the following filling after this time. The value entered here shall be less than or equal to the value calculated at the OIML R-61 section A.5.3.5 for approved usage and stated in section 3.

2.2.12 Gross / Net indication device

If the instrument has Gross / Net key on it, the weight display can be switched from net indication to gross indication for five seconds by pressing the Gross / Net key.

2.2.13 Keyboard functions

According to the software of the instrument, the keys have various functions.

All key functions are described in the keyboard drawings in the manual of the FT-13 indicator.

2.2.14 Real time clock

If it is available in the variant, the real time clock can be activated to get print out with day and time information.

2.2.15 Printing

The instrument can be connected to serial printers with the proper interface. It can be programmed to print date and time of weighing, consecutive number of printing that may be required together with weight / filling results.

Printing is not possible when the indicator is not stable or the display has a negative value.

2.2.16 Gravity acceleration

The gravity acceleration adjustment parameter can be used to compensate the weight difference between the place in which the instrument is calibrated and the place of usage. There is one parameter for this adjustment. The value entered in to this parameter before calibration is considered as a reference value. After calibration, the value in the parameter is seen as 0. For gravity adjustment, the new value must be entered in to this parameter after calibration. After entering the new value, the calibration is automatically adjusted for the place of usage.

2.2.17 Adjusting device

Regarding the connection of the scale, the metrological relevant adjustment is filed in the memory of the evaluation electronics. The access to this adjusting mode or a change of these metrological adjustments is only possible after the short circuit of the calibration jumper.

2.2.18 Units

The family may be produced in any unit legally accepted in EU as kg, g, t, lb etc.

2.2.19 Software

The software versions of the FT-13 weighing indicator are displayed at start-up.

The software version of the FT-13 firmware is 02.xx, and the software version of the FT-13 application is 01.yy, where xx and yy are sub-revision numbers for software changes not related to the legal functionality of the software.

3. Technical data

The following technical data apply for FT-13 and an automatic gravimetric filling instrument based on it:

3.1 FT-13 based automatic gravimetric filling instrument

Reference class:	0.2 or 0.5 or 1 or 2
Maximum capacity (Max):	= $n \times d$
Minimum capacity (Min):	= Minfill
Verification scale interval (d):	≥ 0.5 g
Weighing range:	Single-interval
Number of Verification Scale Intervals (n):	≤ 6000
Maximum tare effect:	≤ 100 % of Max
Temperature range:	-10° to 40° C
Weighing mode:	static
Electromagnetic class:	E2
Humidity:	Non-condensing
Maximum time between automatic zero-setting:	90 minutes

Rated minimum fill (Minfill):

d [g]	Reference accuracy class							
	X(0.2)		X(0.5)		X(1)		X(2)	
	d	[kg]	d	[kg]	d	[kg]	d	[kg]
0.5	56	0.028	22	0.011	11	0.0055	6	0.003
1	111	0.111	22	0.022	11	0.011	6	0.006
2	167	0.334	22	0.044	11	0.022	6	0.012
5	333	1.665	67	0.335	22	0.11	6	0.03
10	333	3.33	133	1.33	33	0.33	11	0.11
20	333	6.66	133	2.66	67	1.34	17	0.34
50	500	25	133	6.65	67	3.35	33	1.65
100	500	50	200	20	67	6.7	33	3.3
200	500	100	200	40	100	20	33	6.6
500	500	250	200	100	100	50	50	25
1000	500	500	200	200	100	100	50	50
≥ 2000	500	$500 \times d$	200	$200 \times d$	100	$100 \times d$	50	$50 \times d$

3.2 Indicator

The indicator has the following characteristics:

Type:	FT-13
Accuracy class:	III and IIII
Weighing range:	Single interval
Maximum number of Verification Scale intervals:	6000
Maximum subtractive tare effect:	-Max, within display limits
Fractional factor:	$p'i = 0.5$
Minimum input voltage per VSI:	0.83 μ V
Minimum input voltage:	0 mV
Maximum input voltage:	20 mV
Excitation voltage:	5 VDC
Analogue range:	0 to 40 mV
Circuit for remote sense:	Active
Minimum input impedance:	58 ohm
Maximum input impedance:	1,200 ohm
Internal resolution:	Up to 8,000,000 counts
Operating temperature range:	-10° C to +40° C, up to 85% humidity non-condensing
Mains power supply:	230 VAC, 50 Hz 60 Hz or 12 VDC or 24 VDC
Peripheral interface:	Set out in section 4

3.2.1 Connecting cable between the indicator and a junction box for load cell(s), if any

Cable between indicator and junction box: 6 wires (sense), shielded

Maximum cable length between indicator and junction box (J-box) for load cell(s), if any:

- Option 1: 715 m/mm²

In case the (n) for the weighing instrument is less than (n) mentioned above, the following apply:

- Option 2:

Coefficient of temperature of the span error of the indicator: $E_s = 0.0044$ [% / 25K]

Coefficient of resistance for the wires in the J-box cable: $S_x = 0.00335$ [% / ohm]

$L/A_{max} = 295.86 / S_x * (emp / n - E_s)$ [m / mm²] in which $emp = p'i * mpe * 100 / e$

From this, the maximum cable length for the weighing instrument may be calculated with regard to (n) for the actual configuration of the instrument.

3.3 Load cells

The FT-13 weighing indicator may only be used with load cell(s) that fulfil the following general acceptance of load cells.

3.3.1 General acceptance of load cells

Any load cell(s) may be used for instruments under this certificate of type approval provided the following conditions are met:

- 1) A test certificate (EN 45501) or a respective OIML Certificate of Conformity (R60) is issued for the load cell by a Notified Body responsible for type examination under the Directive 90/384/EEC.
- 2) The certificate contains the load cell types and the necessary load cell data required for the manufacturer's declaration of compatibility of modules (WELMEC 2, Issue 4, 2004), and any particular installation requirements). A load cell marked NH is allowed only if humidity testing to EN 45501 has been conducted on this load cell.
- 3) The compatibility of load cells and indicator is established by the manufacturer by means of the compatibility of modules form, contained in the above WELMEC 2 document, or the like, at the time of EC verification or declaration of EC conformity of type.
- 4) The load transmission must conform to one of the examples shown in the WELMEC 2.4 Guide for load cells.

3.4 Load receptors

The FT-13 weighing indicator may only be used with a load receptor that has a the load transmission device in accordance with the standard solutions shown in WELMEC Guide 2.4:2001.

3.5 Composition of modules

Composition of modules to an automatic gravimetric filling instrument using FT-13 shall satisfy WELMEC 2 (Issue 4) 2004, paragraph 11.

4. Interfaces and peripheral equipment

4.1 Interfaces

One or more of the following interfaces may be incorporated. The interfaces are protective interfaces within the meaning of EN 45501 sect. 5.3.6.1 and need not to be secured.

4.1.1 Serial interface

Indicator can be equipped with up to three types of serial bidirectional interfaces. These interfaces can be RS 232, RS 422 / RS 485 and / or 20 mA CL ASCII. They are configurable as continuous, demand mode in ASCII or EPL, host mode, Modbus RTU according to the hardware, software options (if any) and the variant. Key functions can be performed via serial interfaces.

4.1.2 Printer interface

If any, serial interface and Ethernet can be used for printer connection.

4.1.3 Digital I/O interface

If the instrument has digital I/O board(s) and connected to external devices, the I/Os can be programmed to control them depending on weight values. The functioning of I/Os is convenient to the purpose of the variant. Key functions can be performed via inputs.

4.1.4 Ethernet interface

The Ethernet interface can be used for all available data output facilities of the instrument.

Key functions can be performed via Ethernet interface.

4.1.5 Profibus

Optionally, the indicator can be connected to the process controllers via profibus interface. The key functions can be performed via profibus interface.

4.1.6 Profinet

Optionally, the indicator can be connected to the process controllers via profinet interface. The key functions can be performed via profinet interface.

4.2 Peripheral equipment

Connection between the indicator and peripheral equipment shall be done by screened cables, except for the Ethernet cable.

The instrument may be connected to any simple peripheral device with a CE mark of conformity.

5. Approval conditions

5.1 The legal metrology parameter (par. 200) must be adjusted as 1

The parameter 200 of the instrument must be adjusted as 1 for usage of the instrument in approved applications.

5.2 Discontinuous totalisation is not approved.

Discontinuous total value is not approved for legal use. It may only be used for monitoring purposes.

6. Special conditions for verification

None.

7. Securing and sealing of FT-13 indicator

7.1 Indicator

Access to the calibration and changing legal metrologically relevant configuration parameters are achieved by the calibration jumper located on the main board. Sealing of this jumper can be done by sticker or lead wire seal.

The analogue load cell connector located on the main board must be sealed by sticker or lead wire seal.

Figure 2 to figure 4 indicate the sealing of FT-13 indicator variants.

7.2 Peripheral interfaces

All peripheral interfaces are “protective”. When the calibration jumper is sealed, they neither allow manipulation with weighing data or legal setup, nor change of the performance of the weighing instrument in any way that would alter the legality of the weighing.

8. Tests performed

Test carried out for this evaluation certificate on indicator FT-.. (DK0199-R76-08.01 rev.1) and indicator FT-13.

Test	Type	Accredited lab.
Temperature effect on sensitivity with minimum weighing range and input impedance of 87 / 350 Ohm (20, 40, -10, 5 and 20 °C)	FT-..	DELTA
Temperature effect on no-load indication with minimum weighing range and input impedance of 87 Ohm (20, 40, -10, 5 and 20 °C)	FT-..	DELTA
Damp heat, steady state	FT-..	DELTA
Repeatability	FT-..	DELTA
Warm-up time	FT-..	DELTA
Span stability	FT-..	DELTA
Cable length between the indicator and junction box	FT-..	DELTA
Stability of equilibrium	FT-..	DELTA
EMC immunity tests are performed with a load cell of 350 Ohm		
Voltage variations (OIML D11:2004, severity level 3)	FT-..	DELTA
Electrical bursts (OIML D11:2004, severity level 3)	FT-..	DELTA
Surge (OIML D11:2004, severity level 3)	FT-..	DELTA
Electrostatic discharge (OIML D11:2004, severity level 3)	FT-..	DELTA
Radiated electromagnetic fields (OIML D11:2004, severity level 3)	FT-..	DELTA
Conducted electromagnetic fields (OIML D11:2004, severity level 3)	FT-..	DELTA
WELMEC Guide 2.8 re-examination to OIML R61:2004	FT-13	DELTA
OIML R61:2004 checklist	FT-13	DELTA
WELMEC Guide 7.2:2008 for type P risk class B	FT-13	DELTA
Material tests	FT-13	DELTA

The test item fulfilled the maximum permissible errors at all tests.

9. Documentation

Contents of the technical documentation held by the notified body in technical file A530528:

10. Pictures



FT-13 Desk type



FT-13 Wall type 1



FT-13 Wall type 2



FT-13 with stand mount kit



FT-13 Stainless steel housing



FT-13 Panel type

Figure 1. FT-13 Indicator enclosures

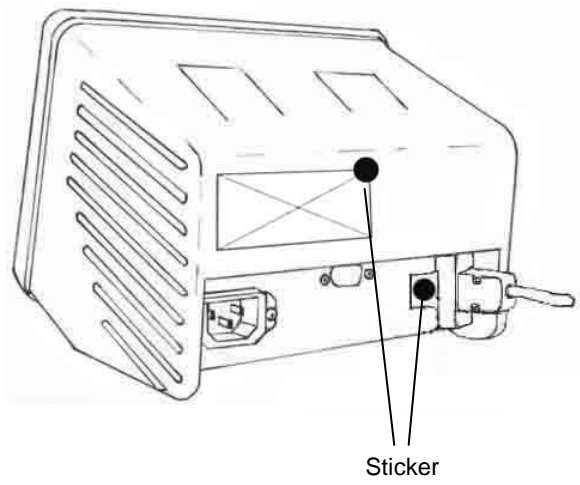
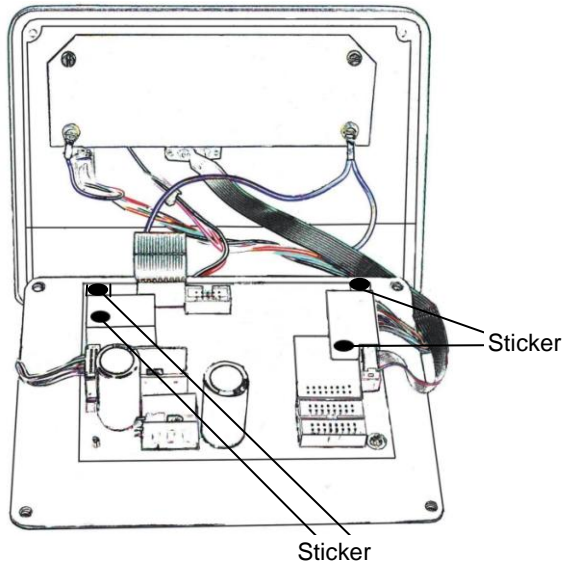

Sealing details with sticker

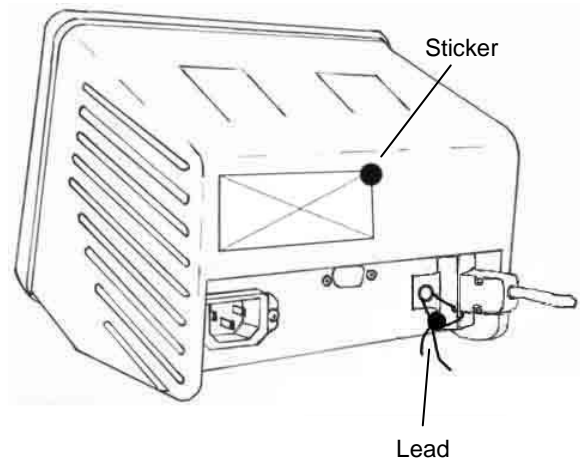
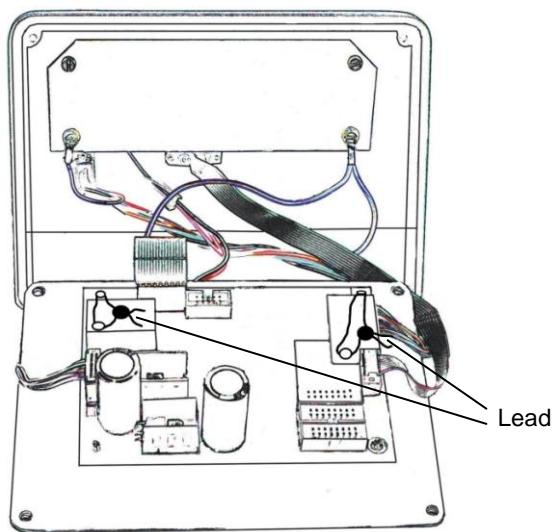

Sealing details with lead

Figure 2. FT-13 aluminium housing sealing details

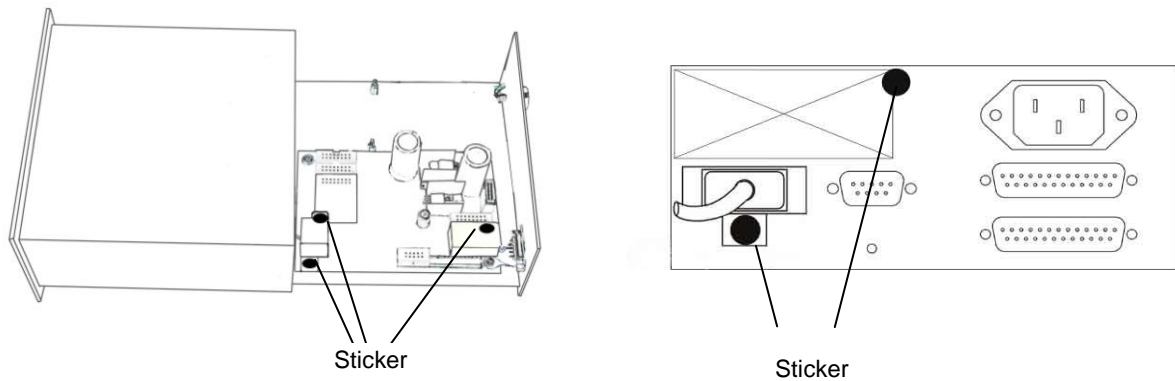

Sealing details with sticker

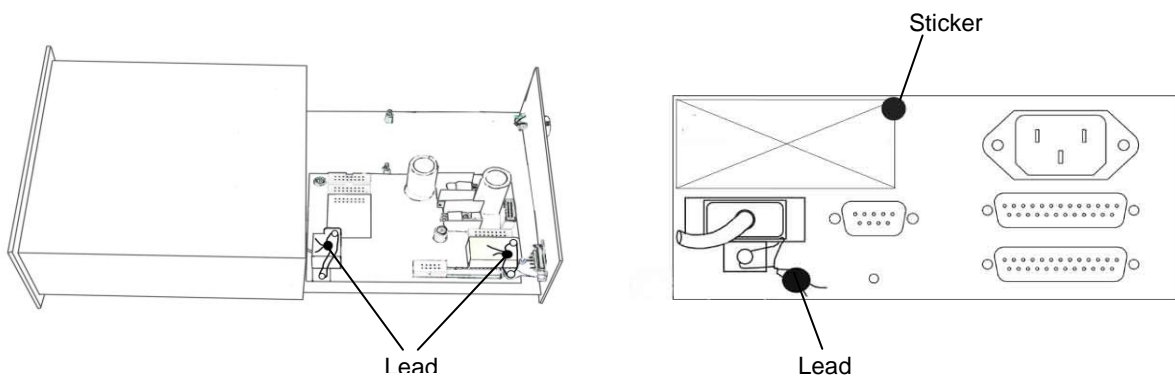

Sealing details with lead

Figure 3. FT-13 panel type sealing details

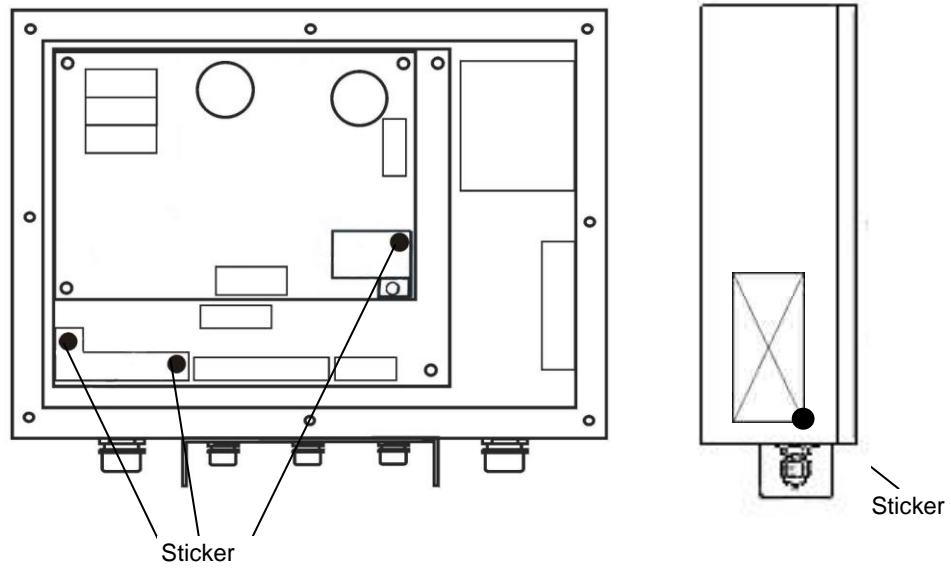

Sealing details with sticker

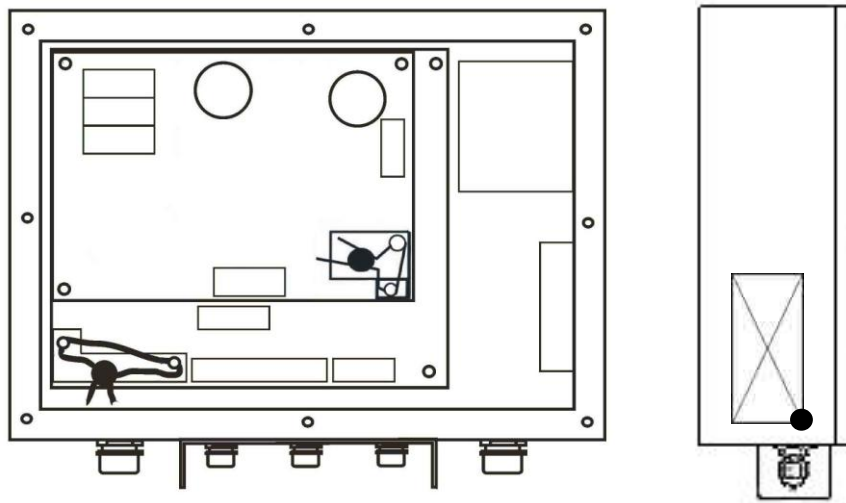

Lead

Sealing details with lead

Figure 4. FT-13 stainless steel housing sealing details