

## **EU-Type Examination Certificate**

### **Measuring Instrument Directive**

**Certificate number: DK-0200-MI004-045**

Issued by FORCE Certification A/S, Denmark  
EU-notified body number 0200

In accordance with the Danish Safety Technology Authority's statutory order no. 544 of May 28, 2018 which implements the Directive 2014/32/EU of the European Parliament and Council of February 26, 2014 on measuring instruments (MID).

**Issued to:**           **Kamstrup A/S**  
**Industrivej 28, Stilling**  
**DK-8660 Skanderborg**

Type of instrument:   Thermal energy meter

Type designation:     MULTICAL® 303

Valid until:           2030-12-17

Number of pages:    17, including appendix

Date of issue:        2022-05-17

Version:              4  
This new version of DK-0200-MI004-045 is issued due to new WELMEC and EN 1434 editions, fast response meter and calibration unit added. Further to this minor editorial changes. The previous certificate is withdrawn.

Approved by



Michael Møller Nielsen  
Certification Manager

Processed by



Lars Poder  
Examiner

The conformity markings may only be affixed to the above type approved equipment. The manufacturer's Declaration of Conformity may only be issued and the notified body identification number may only be affixed on the instrument when the production/product assessment module (D or F) of the directive is fully complied with and controlled by a written inspection agreement with a notified body. This EU-type examination certificate may not be reproduced except in full, without written permission by FORCE Certification A/S.

FORCE Certification references:  
TASK no.: 120-36040.05 and ID no.: 0200-MID-10526-4

## Appendix to

### EU-Type Examination Certificate Measuring Instrument Directive

**Number: DK-0200-MI004-045**

Issued by FORCE Certification A/S, Denmark  
EU-notified body number 0200

Revision	Issue date	Changes
DK-0200-MI004-045	2020-12-17	Original certificate
DK-0200-MI004-045 ver 1	2021-01-20	New software version added, minor editorial changes
DK-0200-MI004-045 ver 2	2021-03-25	New software version added, minor editorial changes
DK-0200-MI004-045 ver 3	2021-06-17	New software version added and tolerances on alternative test points added
DK-0200-MI004-045 ver 4	2022-05-17	New WELMEC 7.2:2021, EN 1434:2007/AC:2007 and FprEN 1434:2022 from 2022-04, fast response meter and calibration unit added. Editorial changes

**Applied standards and documents:**

- EN 1434:2007/AC:2007
- EN 1434:2015+A1:2018
- FprEN 1434:2022 from 2022-04
- WELMEC 7.2:2021

The instruments/measuring systems shall correspond with the following specifications:

**Type designation:**

MULTICAL® 303

**Description:**

The meter consists of a calculator and a flow sensor, which make out a thermal energy meter together with a type approved Pt500 temperature sensor pair.

The electrical connection between the calculator and the flow sensor is a 150 cm long cable, and the units can either be physically assembled or mounted separately.

The calculator unit has a display indicating registered thermal energy, and additionally via a pushbutton also accumulated volume, operating hour counter, inlet and outlet temperatures etc.

The calculator is available with either M-Bus or wireless M-Bus.

The volume measurement is made by means of bi directional ultrasonic technique according to the transit time method. Through two ultrasonic transducers, the sound signals are sent both with and against the flow direction. The flow sensor consists of a meter case made of brass, in which the ultrasonic elements are placed. The heat meter version has a rail for mounting the calculator directly on the flow part.

**Technical documentation:**

Reference No.:

- 120-36040.05
- 120-36040.04
- 120-36040.03
- 120-36040.02
- 120-36040.01

**Technical data**

Legal measuring data according to		: EN 1434:2007/AC:2007 : EN 1434:2015+A1:2018 : FprEN 1434:2022 from 2022-04
Instrument type		: Complete instrument or : Combined instrument or : Hybrid instrument
Parts:		
Calculator and flowsensor or		: DK-0200-MI004-045
Calculator, flow sensor and temp. sensor		: DK-0200-MI004-045, -036 or -046
Accuracy class		: 2 and 3
Environment class		: E1, M1 and M2
Climatic class		: 5...55 °C, non-condensing, closed location and : 5...55 °C, condensing, closed location
Protection class		: Flow sensor IP68 : Calculator IP65
Energy indication		: kWh, MWh or GJ
Temperature range, calculator	$\theta_{\min} \dots \theta_{\max}$	: 2...180 °C (or narrower range)
Temperature difference range	$\Delta\theta_{\min} \dots \Delta\theta_{\max}$	: 3...178 K (or narrower range)
Temperature difference cut-off		: 0.00...2.50 K configurable (default 0.00 K)
Temperature sensors		: 2 paired Pt500 sensors Max 3 m unshielded 2-wire cable
Flow sensor, position		: Inlet or outlet pipe
Straight inlet requirement		: 0D (No requirements for straight inlet)
Installation angle for flow sensor		: Horizontally, vertically or at an angle
Temperature of medium flow sensor	$\theta_q$	: 2...130 °C (or narrower range), 303-W/T 2...50 °C (or narrower range), 303-C
Pressure stage		: PN16/PN25, PS25
Nominal volume flow rate	$q_p$ [m <sup>3</sup> /h]	: 0.6 1.5 2.5
Pressure loss	$\Delta p$ [bar]	: 0.03 0.09 0.09
Dynamic range, $q_p$ 0.6	$q_p:q_i$	: 100:1 or 50:1
Dynamic range, $q_p$ 1.5 -2.5	$q_p:q_i$	: 250:1 or 100:1 or 50:1
	$q_s:q_p$	: 2:1

**DK-0200-MI004-045**

Durability specification	: Minimum 10 years (Long life flow sensor)
Fast response meter (Config L=7)	: DS temp. sensor response time $\tau_{0.5} \leq 2.5$ s : Temperature sampling interval $\leq 4$ s : Volume sampling interval $\leq 1$ s : Integration time $\leq 4$ s
Provision for direct temperature (DS) sensor in the flow sensor (M10x1 connection)	: G $\frac{3}{4}$ B - G1B Threaded flow sensors
Power supply options	: 3.65 VDC, Lithium battery 1 x A-cell or 2 x A-cell

**Software identification**

Software revision	J1 (1001)	1 0 0 1
Kamstrup Internal Item No.	50981603	1 6 0 3
		↓
Software Identification		1 6 0 3 1 0 0 1

*The Software identification and checksum can be shown on the display of the calculator  
(display No. 10 and No. 11)*

Software Identification	Date	CRC-16 sum <sup>1)</sup>	Description
16030501 (E1)	2020-06-26	54156	N: Initial release
16030601 (F1)	2020-12-22	40356	N: Second release

Software Identification	Date	CRC-32 sum <sup>1)</sup>	Description
16030701 (G1)	2021-03-05	F8602cd6	N: Third release. For production.
16030801 (H1)	2021-06-09	Cb7A19b0	N: Fourth release. For production.
16031001 (J1)	2021-12-20	dd35C2Cb	N: Fifth release. For production.

<sup>1)</sup> The CRC-16 is displayed in decimal and the CRC-32 is displayed in hexadecimal values. The CRC-32 is shown in upper/lower case as the letters appears on the meters 7-segment display.

N: Non-legally Relevant Software change

L: Legally Relevant Software change

**Type number combination MULTICAL® 303**

			<i>Static data</i> <b>303-XXXXXX</b> Printed on the meter				<i>Dynamic data</i> - <b>XXXXXX</b> Displayed			
			□	□□	□	□□	□□	□	□□	
<b>Type 303-</b>										
<b>Sensor connection</b>										
Pt500 Heat meter			W							
Pt500 Heat/Cooling meter			T							
Pt500 Heat/Cooling meter			C							
<b>Flow sensor</b>										
	Connection	Length								
q <sub>p</sub> [m <sup>3</sup> /h]		[mm]								
0.6	G <sup>3</sup> / <sub>4</sub> B (R <sup>1</sup> / <sub>2</sub> )	110		1X						
1.5	G <sup>3</sup> / <sub>4</sub> B (R <sup>1</sup> / <sub>2</sub> )	110		4X						
1.5	G1B (R <sup>3</sup> / <sub>4</sub> )	130		7X						
2.5	G1B (R <sup>3</sup> / <sub>4</sub> )	130		AX						
<b>Meter type</b>										
Heat meter (MID module B, prepared for module F)									1	
Heat meter (MID module B+D)									2	
Heat meter with additional cooling register (MID module B+D) θ <sub>nc</sub> =OFF									3	
Heat meter with additional cooling register (MID module B+D) θ <sub>nc</sub> =ON									6	
<b>Country code</b>							XX			
<b>Temperature sensor pair</b>								XX		
<b>Supply</b>										
Battery, 1xA-cell									1	
Batteries, 2xA-cells									9	
<b>Communication (Built-in)</b>										
Wired M-Bus, configurable									20	
Wireless M-Bus, configurable, 868-870 MHz									30	

**Verification**

Errors: [Maximum permissible errors according to Directive 2014/32/EU of the European Parliament and Council of February 26th, 2014 on measurement instruments (MID), Annex VI MI-004]

Procedure: (Test points and verification requirements according to EN 1434-5)

Complete meter according to: [3.] (6.7)

Hybrid and combined instrument according to: [7.1] (6.2), [7.2] (6.3), [7.3] (6.4), (6.5)

**Alternative test points**

	Inlet	Outlet		Inlet	Outlet		Inlet	Outlet
	a) 44.3 °C	41 °C	or	a) 43 °C	40 °C	or	a) 43 °C	40 °C
	b) 80 °C	65 °C		b) 50 °C	40 °C		b) 50 °C	40 °C
	c) 160 °C	20 °C		c) 130 °C	40 °C		c) 160 °C	40 °C
or	Inlet	Outlet	or	Inlet	Outlet	or	Inlet	Outlet
	a) 53 °C	50 °C		a) 43 °C	40 °C		a) 43 °C	40 °C
	b) 70 °C	50 °C		b) 110 °C	40 °C		b) 110 °C	40 °C
	c) 130 °C	20 °C		c) 130 °C	40 °C		c) 160 °C	40 °C

*Tolerances on simulated temperatures: ± 1 °C. Tolerances on temperature differences shall follow EN1434-5.*

During verification of the flow sensor a water temperature of 20 ± 5 °C can be used.

For dynamic ranges  $q_p:q_i$  100:1 and 50:1, the dynamic range 100:1 can be used.

For dynamic ranges  $q_p:q_i$  250:1 and 100:1 and 50:1, the dynamic range 250:1 can be used.

The temperature reading can be offset adjusted from -0.99...0.99 K, commonly for the inlet and outlet, in order to compensate for the sensor cable influence on the absolute temperature. During change of temperature sensor pairs it is recommended to adjust to meters offset temperature according to the newly mounted sensor pair. Alternatively adjust the offset to 0.00 K whereby the function is disabled (OFF).

Example: If the temperature sensor pair has an error at +0.20 K at zero, then the meters offset should be -0.20 K in order to compensate.



**Installation angle**

The flow sensor can be installed horizontally, vertically or at an angle



The flow sensor can be turned up to max. 45° and down to max. 90° in respect to the pipe axis.

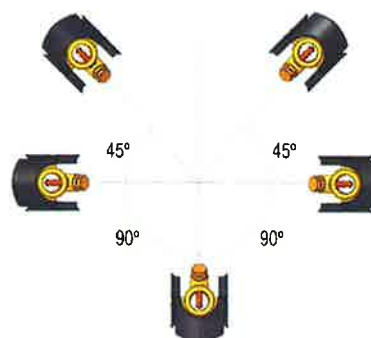

After verification, but before commissioning, the meter can be reprogrammed with a view to:

Placing of flow sensor in inlet pipe or outlet pipe, measuring unit of energy indication (kWh, MWh or GJ)\* and decimal point in energy\* and volume\* indication\*

Mounting the flow sensor in Inlet or in Outlet:



If the meter is set to be an inlet meter, the "Inlet arrow" is displayed.



If the meter is set to be an outlet meter, the "Outlet arrow" is displayed.

\*) Register resolution requirements according to EN 1434 must be observed

## Test description

MULTICAL<sup>®</sup> 303 can be tested as a complete meter, as a hybrid meter or as a combined meter depending of the approval or the available test equipment.

Before test as a complete meter the "TEST" seal must be broken (see "Test mode"). The high-resolution test registers can be read from the display, via serial data reading, or via high-resolution pulses.

Before test as a hybrid meter, the temperature sensors should be removed from MULTICAL<sup>®</sup> 303. Subsequently, the calculator is tested separately by means of precision resistors and the meter's built-in "Auto-integration". Flow sensor and temperature sensors are tested separately too.

By means of the push-button on the front of the meter you can choose between four display loops. No matter which display you have selected you can change to User-loop by pressing the push-button for 5 sec. until "1-User" is displayed and then releasing the button. If the button is pressed for 7 sec. instead, "2-Tech" is displayed, and if you release the push-button now, you have access to Tech loop.

In order to obtain quick test/verification of MULTICAL<sup>®</sup> 303, the meter has a test mode which repeats the measuring sequence every four seconds, i.e. eight times faster than in normal mode. In test mode heat energy, cooling energy and volume are displayed with a resolution which is higher than normal in order to enable shorter test duration.

In order to access test mode the "TEST" seal  on the back of the meter must be carefully broken with a screwdriver and the contact points behind the seal short-circuited with a short-circuit pen or a screwdriver.

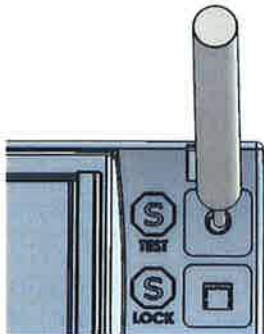

Subsequently, test is displayed.

4 - E E 5 E

The meter remains in test mode until the front button is activated for 5 sec. However, a time-out secures that the meter returns from test mode to normal mode after 9 hours.

When tests are finished the seal must be re-established using a void label size 15 x 15 mm. The seal is important with a view to the meter's approval.

## Test loop



Test loop includes six different main readings and three different sub-readings:

Test loop (Loop_4) Main		Test loop (Loop_4) Sub		Index number in display
1.0	High-resolution heat energy *)			4-001
		1.1	Heat energy (E1)	4-001-01
2.0	High-resolution cooling energy *)			4-002
		2.1	Cooling energy (E3)	4-002-01
3.0	High-resolution volume *)			4-003
		3.1	Volume	4-003-01
4.0	t1 (Inlet)			4-004
5.0	t2 (Outlet)			4-005
6.0	Flow			4-006

After 9 hours the meter reverts to energy reading in "User loop".

\*) Register/resolution of the high-resolution registers are as follows: "0000001 Wh" and "00000.01 l"

Test-loop can only be displayed if the verification seal is broken and the switch activated. The high-resolution registers can only be reset in connection with a total reset.

### Test connection

During test either optical reading head with USB plug (66-99-099) for serial reading of high-resolution energy and volume registers, or Pulse Interface (66-99-143) with optical reading head and connection unit for high-resolution pulse outputs is used. Do not forget that the meter must be in Test mode.



### Verification pulses

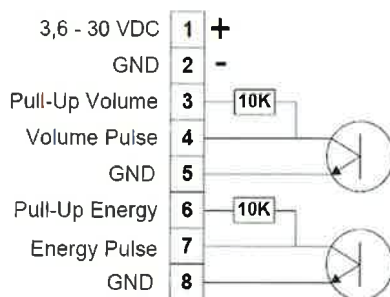

When Pulse Interface type 66-99-143 is connected to power supply or battery, the unit is placed on the meter, and the meter is in test mode, the following pulses are transmitted:

- High-resolution energy pulses (1 Wh/pulse) on terminals 7 and 8
- High-resolution volume pulses (10 ml/pulse) on terminals 4 and 5

**Pulse Interface 66-99-143, technical data**

Supply voltage	3.6 – 30 VDC
Current consumption	< 15 mA
Pulse outputs	< 30 VDC < 15 mA
Pulse duration	3.9 ms.
Energy pulse	1 Wh/pulse (1000 pulses/kWh)
Volume pulse	10 ml/pulse (100 pulses/litre)

Use of high-resolution pulses

High-resolution energy and volume pulses can be connected to the test stand used for calibration of the meter, or to Kamstrup Pulse Tester, type 66-99-279, as shown in the drawing below.

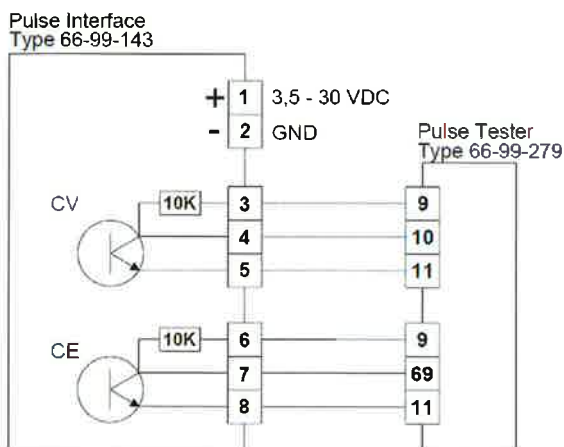

Auto-integration

The purpose of auto-integration is to test the calculator's accuracy. During auto-integration the water flow through the meter must be cut off to make it possible to read the volume and energy counted during auto-integration without the meter continuing normal counting in the registers afterwards.

At the beginning of an auto-integration the meter receives a serial data command with test volume and number of integrations over which the meter is to distribute the volume.

After auto-integration all volume and energy registers – incl. the high-resolution test registers – have been enumerated by the given volume and the calculated energies. Furthermore, the average of the temperatures measured during auto-integration has been saved in two registers, "t1 average inlet temperature" and "t2 average outlet temperature".

For calculation of accuracy the below-mentioned registers can be read after auto-integration:

Verification registers	
Heat energy	E1HighRes
Cooling energy	E3HighRes
Volume	V1HighRes
t1 average inlet temperature	t1average_AutoInt
t2 average outlet temperature	t2average_AutoInt

### Handling different test methods

#### Standing start/stop

Standing start/stop is a method used for testing the flow sensor's accuracy. During the test the meter must be mounted in a flow test stand. The flow through the sensor is cut off. Subsequently, water flow is added for a certain period, during which the water passing through the sensor is collected. Having switched off the flow, the volume of the collected water is compared to the volume counted by the meter. In general, standing start/stop requires bigger test volume than flying start/stop.

#### Standing start/stop via display reading

Condition: MULTICAL® 303 must be in test mode (see "Test mode").

The high-resolution display readings are updated at 4-second intervals.

#### Standing start/stop using pulse outputs

Condition: MULTICAL® 303 must be in test mode (see "Test mode").

Verification pulses are connected as described in "Verification pulses" above.

#### Flying start/stop

Condition: MULTICAL® 303 must be in test mode (see "Test mode").

Verification pulses are connected as described in "Verification pulses" above.

"Flying start/stop" is the most frequently used method for testing the accuracy of flow sensors. During the test the meter must be mounted in a flow test stand and there is constant water flow through the sensor.

Verification pulses, as described in "Verification pulses", can be directly used for the test stand if it is designed to control the start/stop synchronisation. Alternatively, Pulse Tester, type 66-99-279, can be used as external start/stop pulse counter.

As the meter calculates volume and energy every four seconds in test mode (see "Test mode"), the verification pulses will also be updated every four seconds as described in "Verification pulses". It is important to allow for this time interval, which means that the test duration from start to stop must be so long that the update time does not influence the measuring uncertainty to any very considerable extent.

**Security measures**

Sealing

<b>S</b>	Security seals. Covering release for PCB box (label or integrated part of PCB box)
<b>D</b>	Module D marking (engraving or separate label)
<b>T</b>	Type marking
<b>I</b>	Installation seals (sealing wire or void labels)
<b>A</b>	Alternative approval marking
<b>R</b>	Re-verification marking

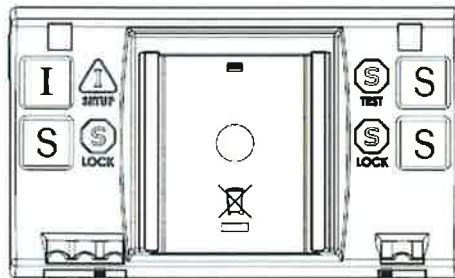
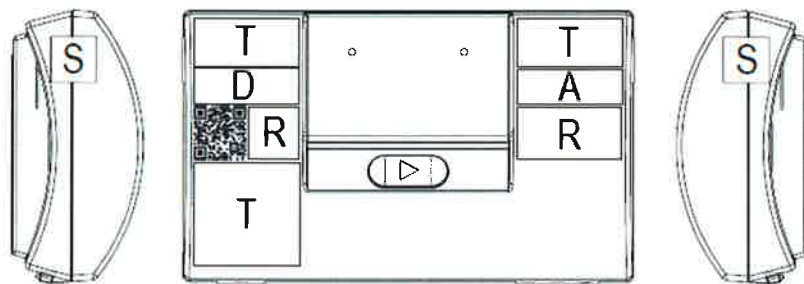

**I** Installation seals (Sealing wire or sealing cap)

Examples

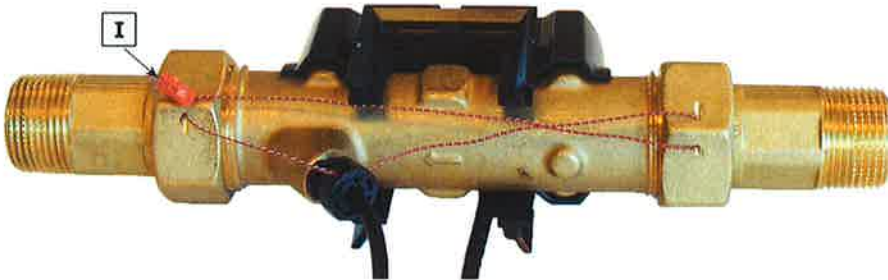

**Inscriptions**

Manufacturer postal address (on the base part/rear side)



Address marking through 2021

- CE marking and the supplementary metrology marking
- System designation (No. of the EU-type Examination Certificate)
- Type, production year and serial number
- Mechanical and electromagnetic environment classes
- Climatic class (in the installation manual)
- Temperature limits ( $\theta_{min}$  ...  $\theta_{max}$ )
- Differential temperature limits ( $\Delta\theta_{min}$  ...  $\Delta\theta_{max}$ )
- Temperature sensor type (Pt500)

Additional info in the display

- Unit of measurement
- Software version

Mounting the flow sensor in Inlet or in Outlet:



If the meter is set to be an inlet meter, the "Inlet arrow" is displayed.

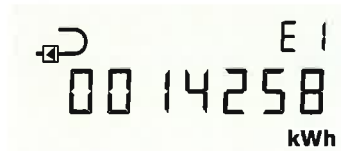

If the meter is set to be an outlet meter, the "Outlet arrow" is displayed.

Example of inscriptions for MULTICAL® 303

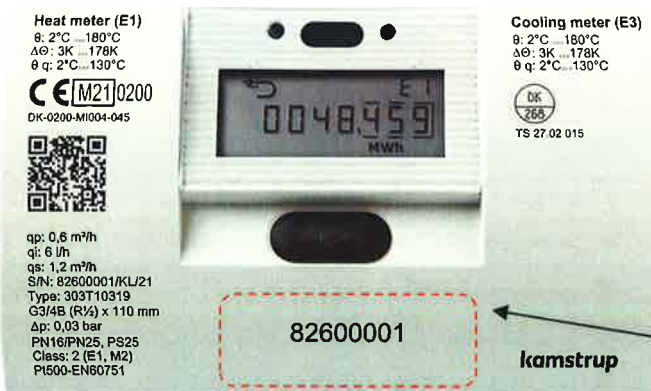

MULTICAL® 303 shown as an example with both the MID mark (to the left) and additional approval mark (to the right) outside the scope of the Measuring Instrument Directive

Customer specific area

Symbols, as an alternative to textual inscriptions, are acceptable, if explained in the installation manual.

**Photos of MULTICAL® 303**

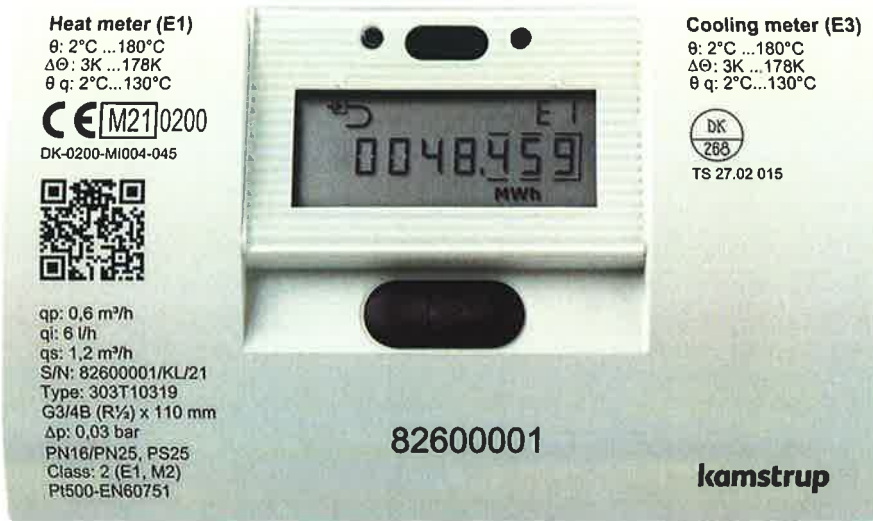

## **Informative Annex**

### **Integrated functions not subject to the Measuring Instruments Directive:**

#### Integrated bi-functional Heat/Cooling function

The MULTICAL® 303 is type tested as Heating, Cooling and as bi-functional Heating/Cooling energy meters according to EN 1434-4:2015+A1:2018 and FprEN 1434-4:2021 from 2021-12-27.

On this basis the energy meter is approved according to national type approval for Cooling according to the Danish law<sup>1</sup>, System designation TS 27.02 015.

The integrated bi-functional Heating/Cooling function can therefore be utilized under the operating conditions as described in this certificate.

The meter is type tested in the temperature differential range  $\Delta\theta_{\min} \dots \Delta\theta_{\max}$ : 2 K...178 K and can be used as so.

#### Re-verification

Re-verification of MULTICAL® 303 may be performed according to EN 1434-5 under the same conditions as stated in this certificate for verification of MULTICAL® 303, under consideration of national law.

Re-verification of the calculator as a heat meter or as a cooling meter is allowed, due to the extended type test.

During re-verification of the flow sensor a water temperature of  $20 \pm 5$  °C can be used.

#### Calibration unit for MULTICAL® 303 as a calculator sub-assembly

Technical description, Document No.: 5512-3271

Type No.: 6699-303 (Pt500 2-Wire)

Temperature test points:

Heat:  $44.3$  °C –  $41$  °C =  $3.3$  K /  $80$  °C –  $65$  °C =  $15$  K /  $160$  °C –  $20$  °C =  $140$  K

Cooling:  $15$  °C –  $18.3$  °C =  $-3.3$  K /  $6$  °C –  $20$  °C =  $-14$  K

---

<sup>1</sup> BEK No. 1178 of 06/11/2014, Ordinance on metrological control of meters used for measuring consumption of cooling energy in district cooling systems and central cooling systems as amended by BEK. No. 549 of 01/06/2016.



Manufacturer or distributors logo

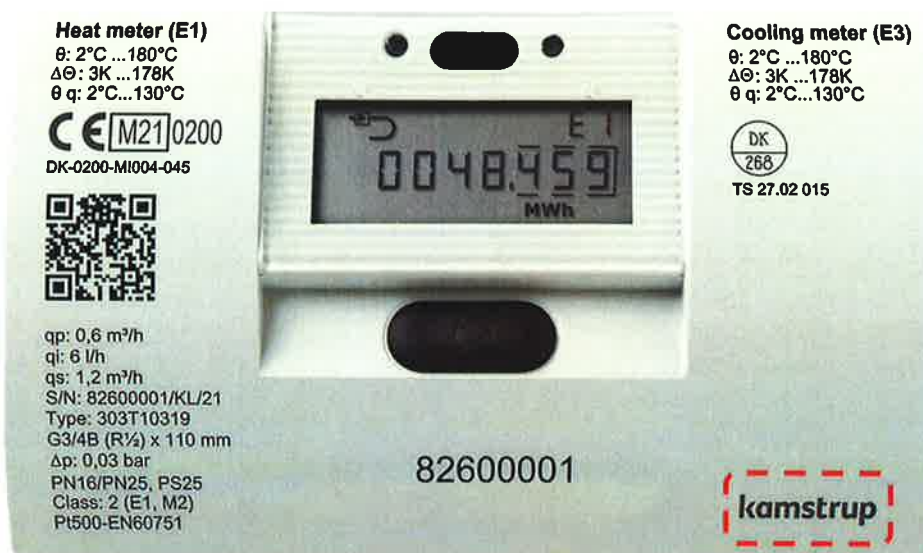

The manufacturer or distributors logo is located at the lower right part of the front, shown in the dotted red marking.

Beside Kamstrup as manufacturer logo, distributor logos from the following companies can be used:

- Schneider
- Berg